

• MAŁY KONSTRUKTOR •
• CONSTRUCTOR •
JUNIOR



4+

102



Nº2588





klucz x 2



D02 x 7



D06 x 2



D03 x 1



D04 x 3



D05 x 2



D07 x 2



WD12H160 x 2



HAK x 1



DL01 x 2



DL02 x 2



0716 X 4



0705 x 4



NP001 x 3



NP001 x 7



NP001 x 4



NP001 x 8

13mm



SP001 x 12

13mm



SP001 x 3

13mm

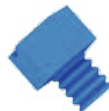

SP001 x 1

13mm



SP001 x 2

24mm



SP004 x 3

24mm



SP004 x 8

33mm



SP002 x 2

33mm



SP002 x 2

54mm

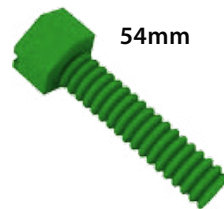

SP003 x 1



KP001 x 6



KP001 x 1



KP001 x 4



KP001 x 3

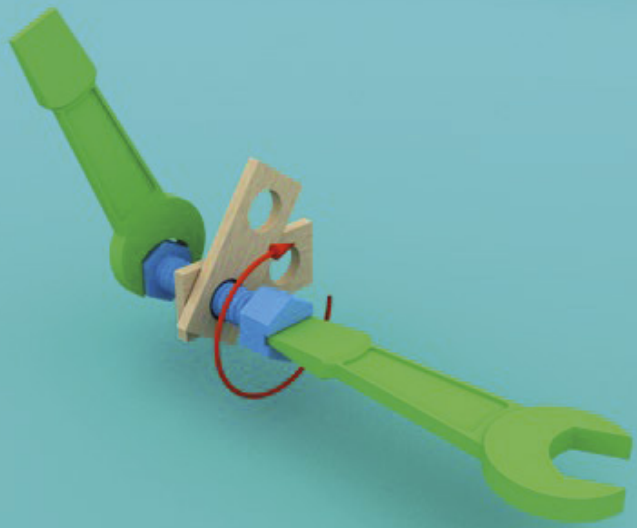

x 2

x 2

x 4

x 3

x 1

D07

D02

KP001

SP004

SP004

KP001

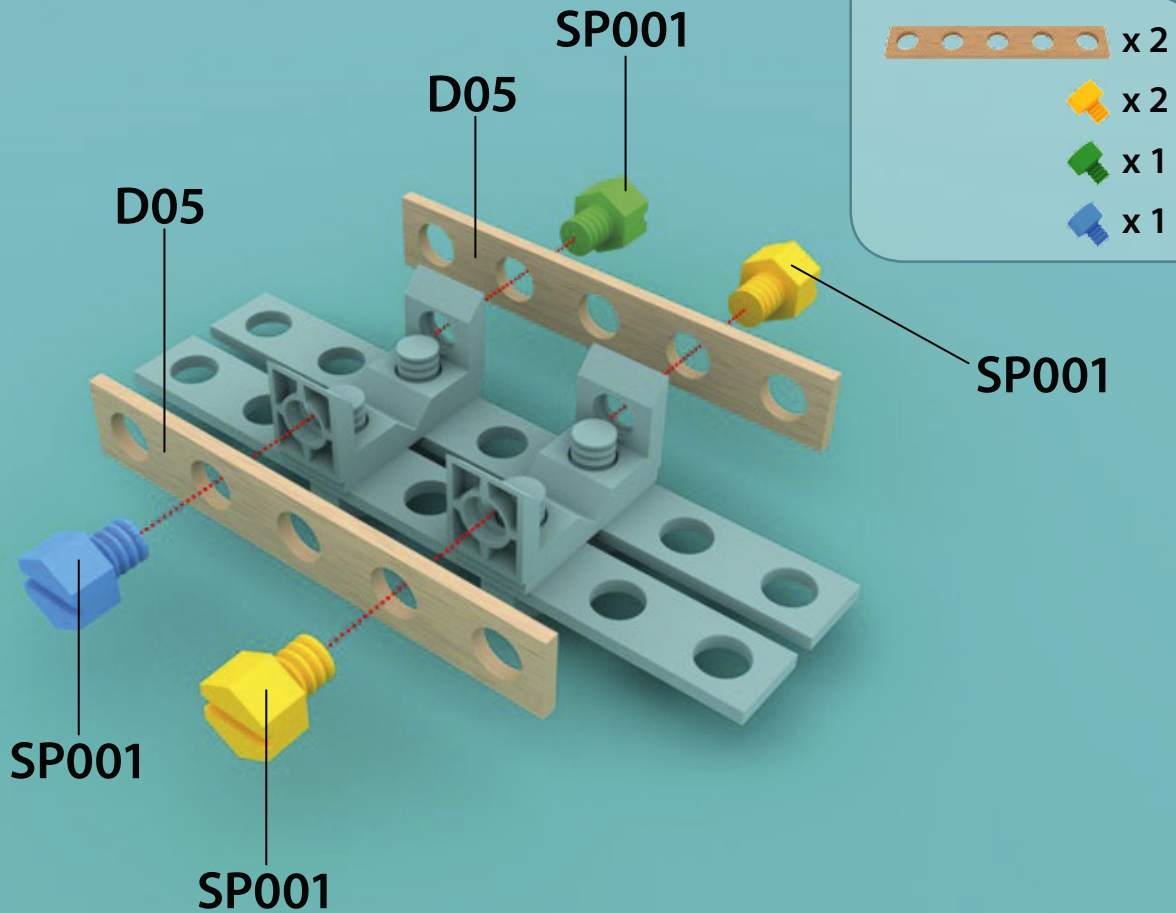

- x 2
- x 1
- x 1

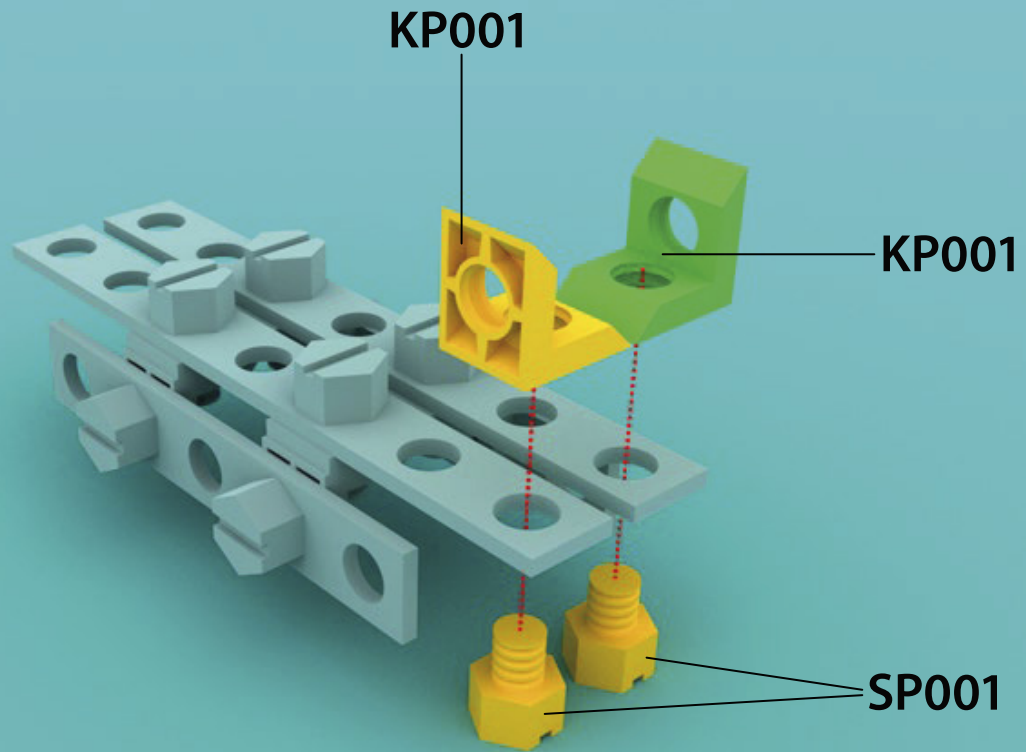

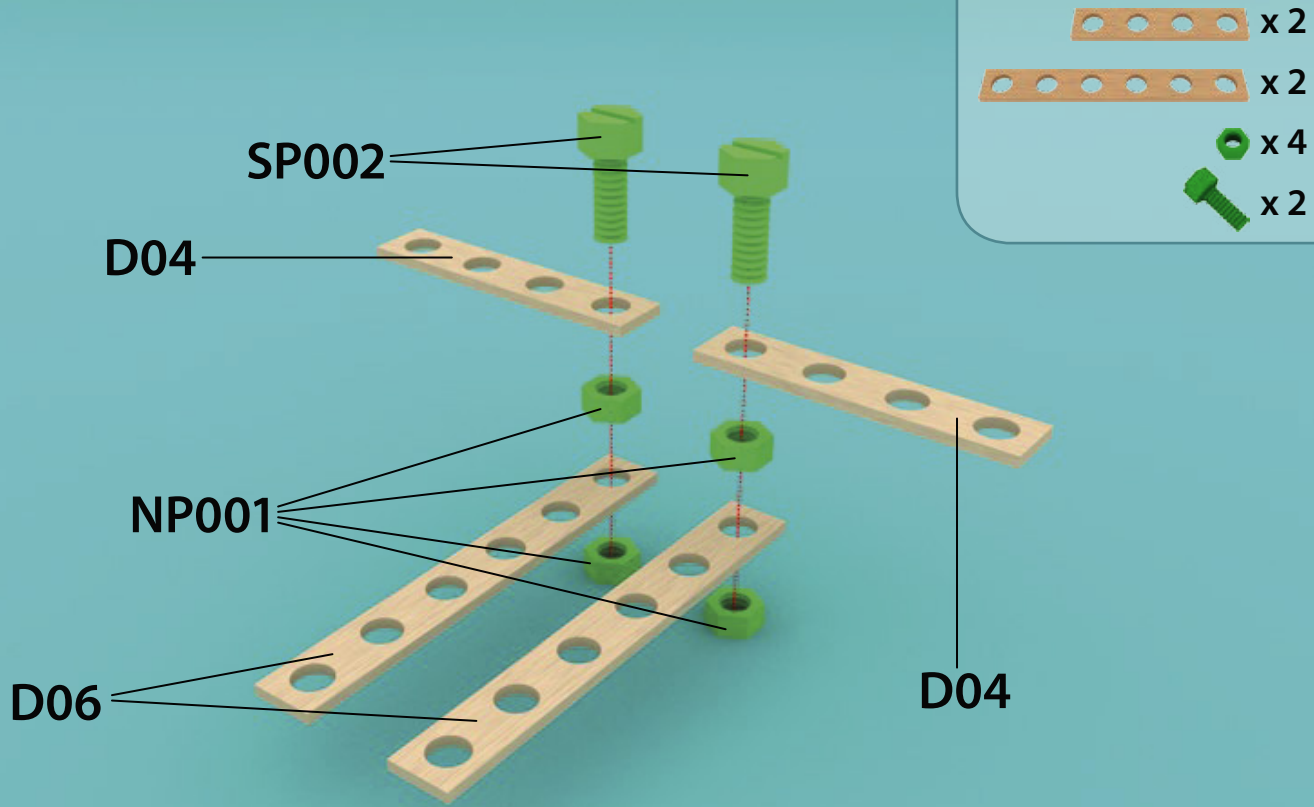

 x 1

 x 2

 x 2

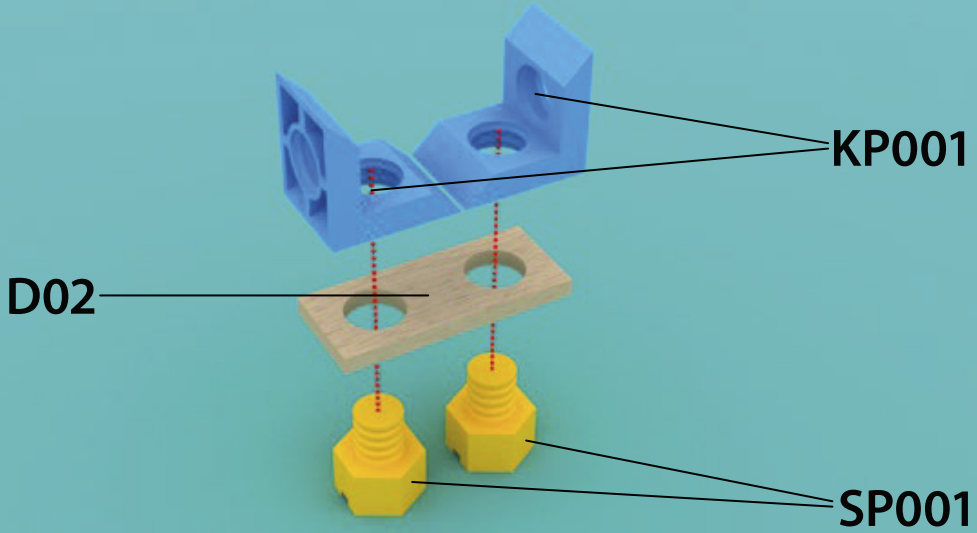



x 1



x 1

SP004

DL02

6

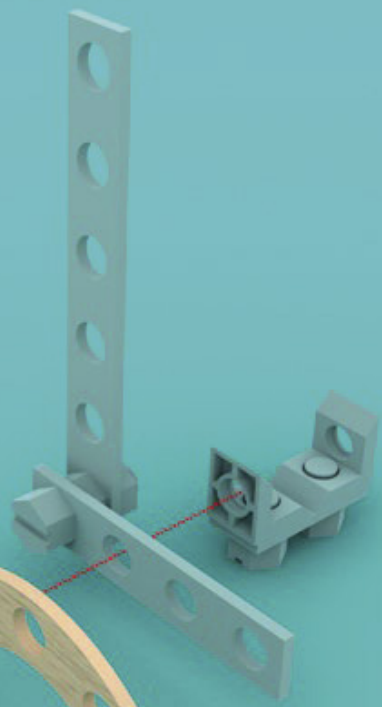



x 1



x 1

DL02

SP004

NP001

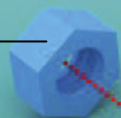

D03

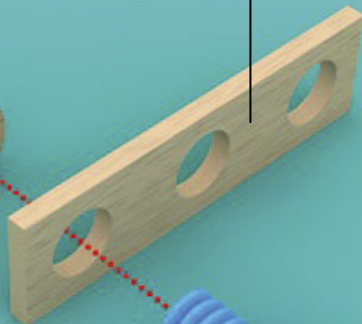

HAK

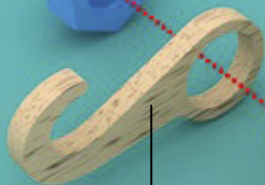

SP004

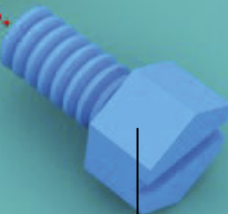

x 1



x 1



x 1



x 1

 x 2

 x 1

 x 1



NP001

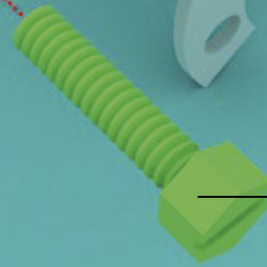

NP001



SP003

 x 2
 x 2

NP001

SP004

SP004

10

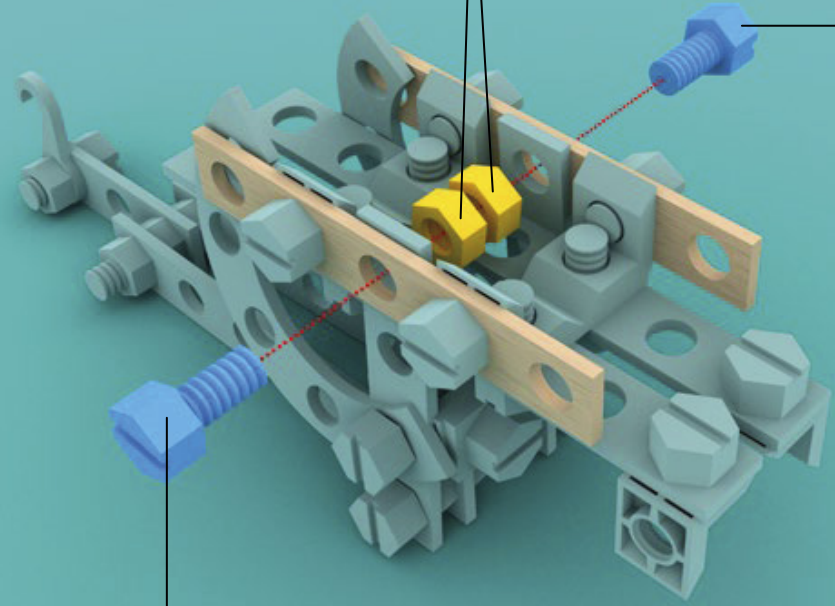



x 2



x 2



x 2



x 2



x 2

SP001

SP001

DL01

KP001

KP001

KP001

KP001

DL01

SP001

SP001



x 1



x 2

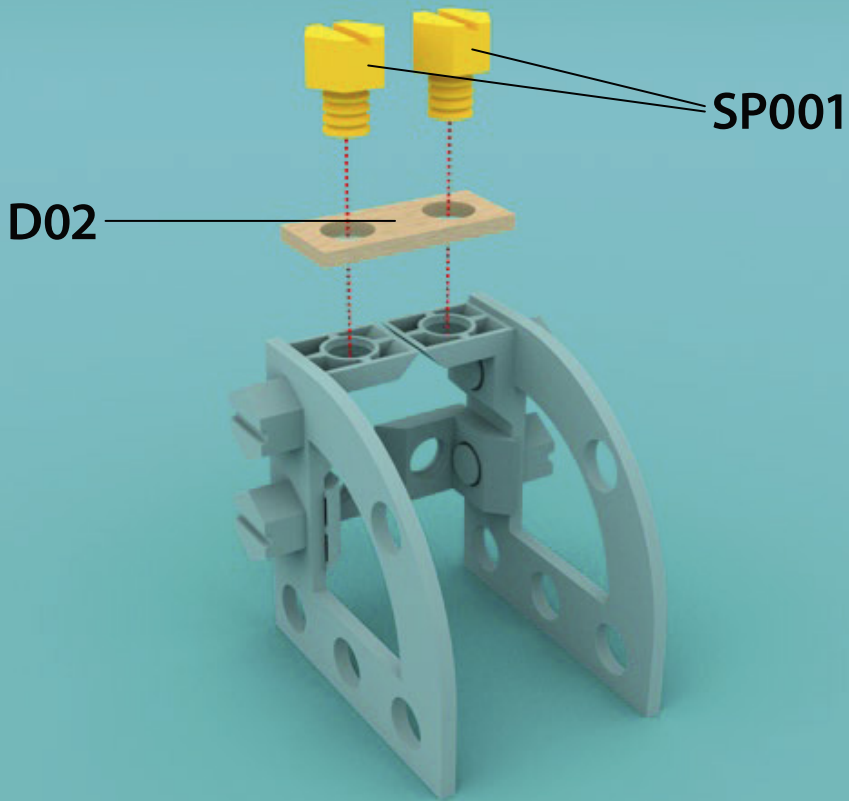

x 2

x 1

x 2

x 1

x 1

x 2

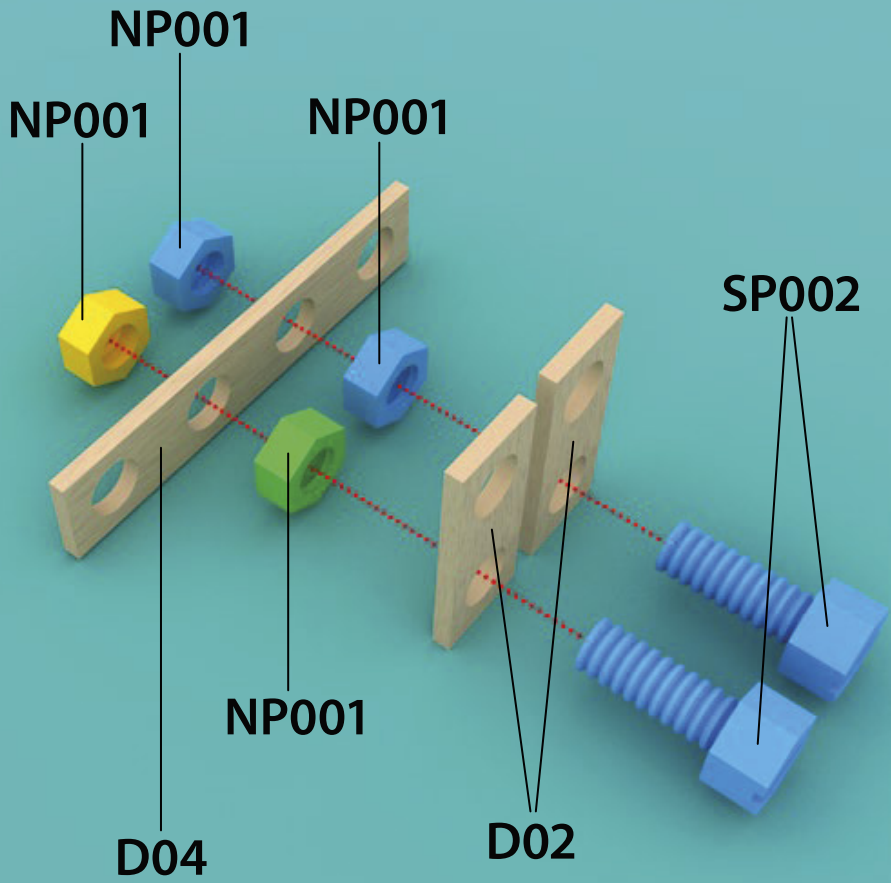





KP001

D02

SP004

KP001

SP004

-  x 1
-  x 1
-  x 1
-  x 1
-  x 1

 x 2

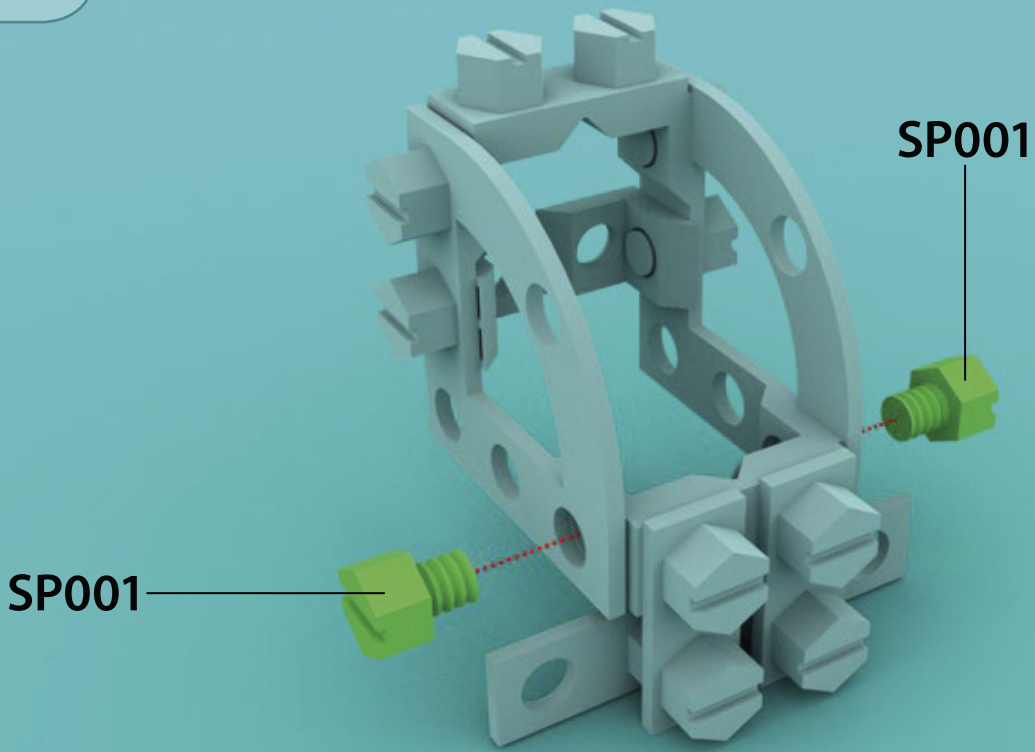

 x 2

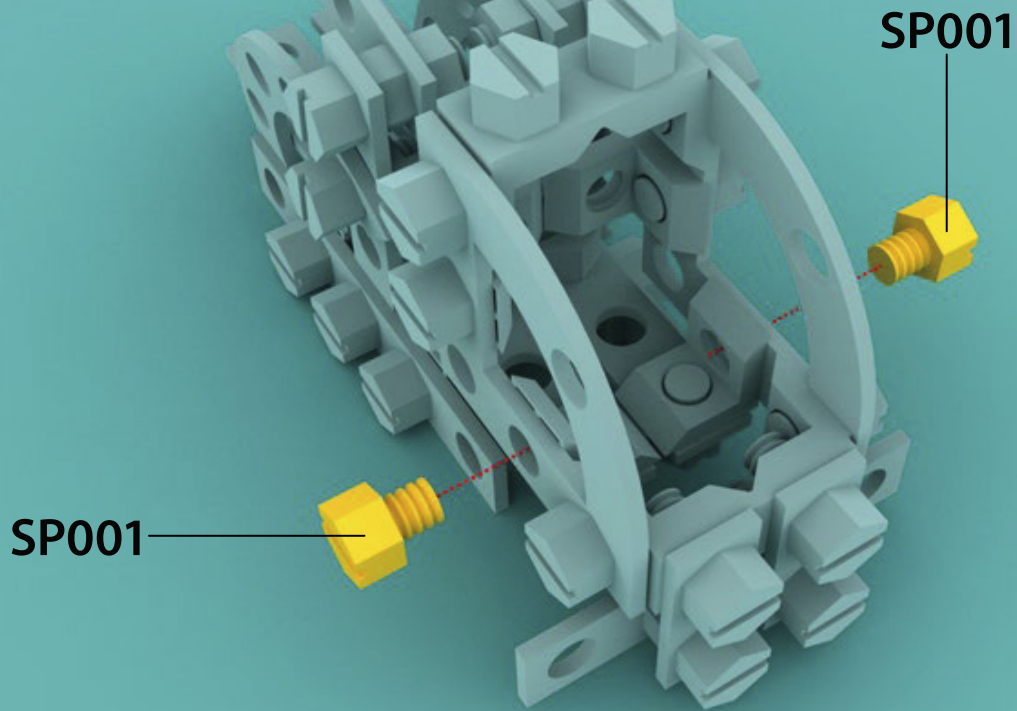

Red circle icon x 3





Blue circle icon x 1

Orange bar icon x 2

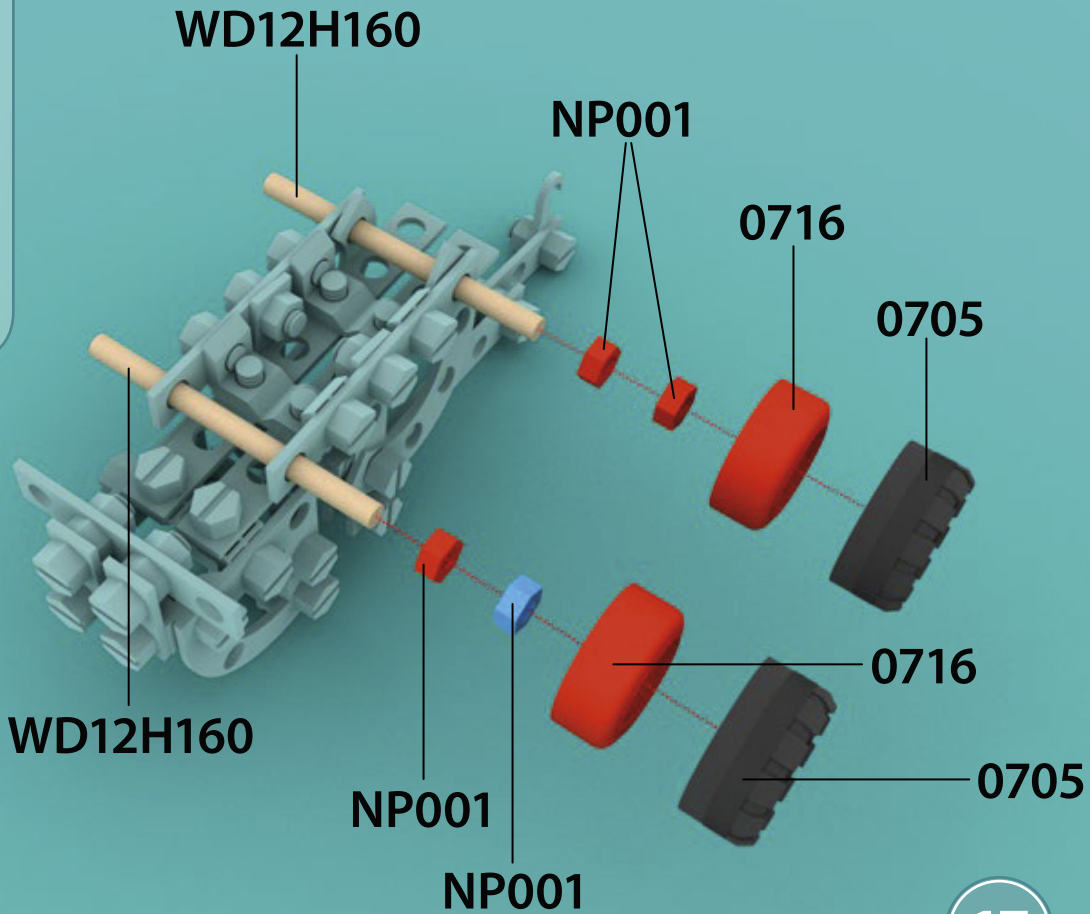
Red cap icon x 2

Black ring icon x 2



-  x 3
-  x 1
-  x 2
-  x 2

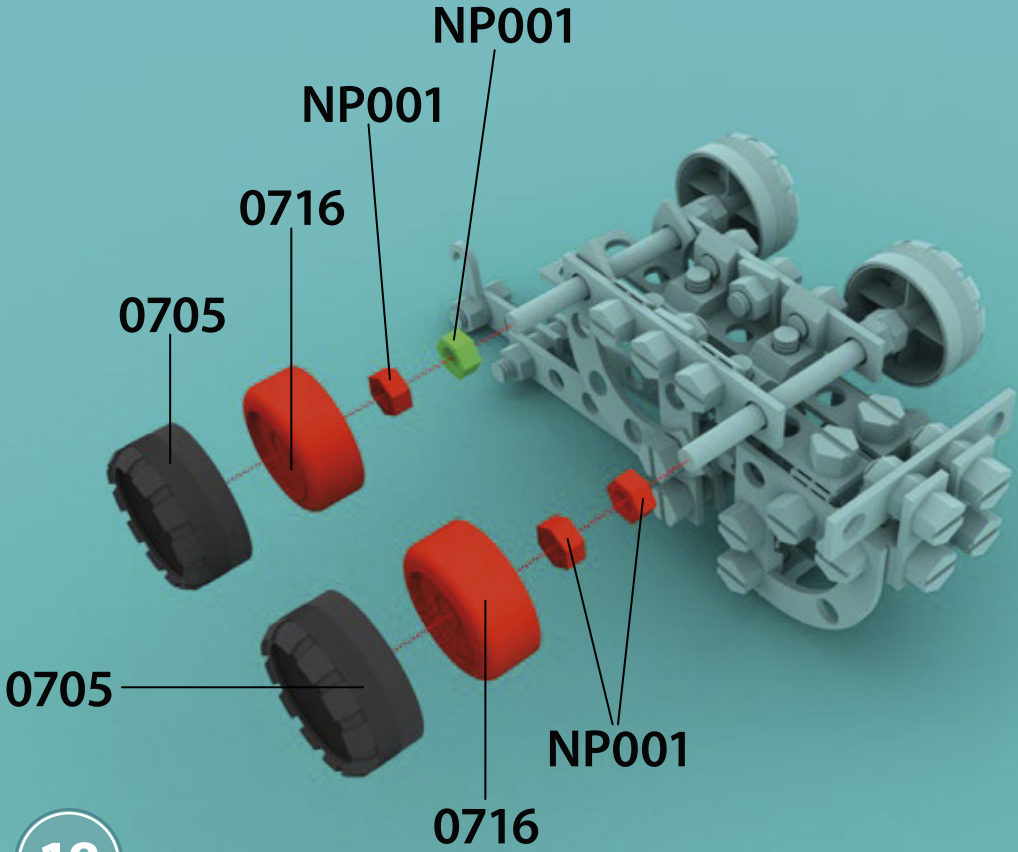



PL: Ostrzeżenia! Nieodpowiednie dla dzieci w wieku poniżej 3 lat. Zestaw zawiera małe elementy – niebezpieczeństwo zakrztuszenia. Prosimy zachować opakowanie ze względu na podane informacje. **EN:** Warnings! Unsuitable for children under the age of 3. Contains small parts – choking hazard. Keep the box for future reference. **DE:** Achtung! Nicht für Kinder unter 3 Jahren geeignet. Enthält kleine Teile, die verschluckt werden können – Erstickungsgefahr. Verpackung für spätere Rückfragen aufbewahren. **FR:** Attention! Ne convient pas aux enfants de moins de 3 ans. Contient des petits éléments pouvant être avalés et engendrer un risque d'étouffement. Documentation à lire et à conserver pour consultation ultérieure. **ES:** ¡Advertencia! No recomendable para niños de 3 años o menores. Peligro de asfixia – piezas pequeñas. Conserve la caja para futuras referencias. **NL:** Waarschuwing! Niet geschikt voor kinderen jonger dan drie jaar. Bevat kleine onderdelen – verstikkingsgevaar opleveren. Bewaar de verpakking, er staat belangrijke informatie op. **CZ:** Upozornění! Nevhodné pro děti do 3 let. Balení obsahuje malé dílky – nebezpečí udušení. Zachovejte prosím obal ze vzhledu na uvedené informace. **SK:** Upozornenia! Nevhodné pre deti vo veku do 3 rokov. Súprava obsahuje malé časti – hrozí nebezpečenstvo udusenía. Obal uschovajte vzhľadom na dôležité informácie, ktoré sa na ňom nachádzajú.



www.alexander.com.pl