



8+
815

SCRATCH

2593



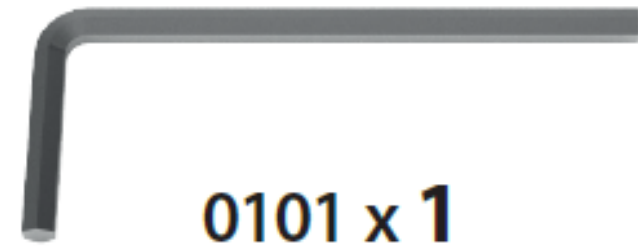

0101 x 1

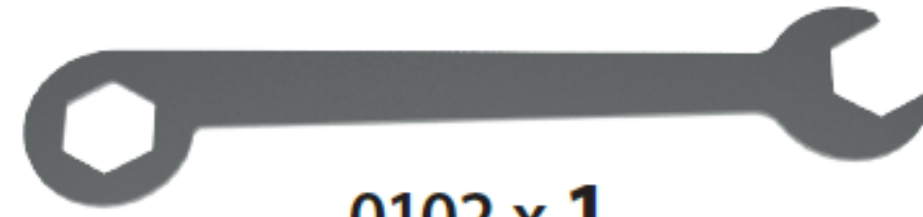

0102 x 1

M4 - 6mm



1001 x 69

M4 - 10mm



1002 x 10

M4 - 12mm



1003 x 6

M4 - 16mm



1004 x 6

M4 - 20mm



1005 x 4



1006 x 95



1007 x 95



0205 x 1



0215 x 2



03F1 x 2



032F x 6



0331 x 1



0341 x 1



03F1R x 8



03P5R x 6



0307 x 4



0309 x 1



033FF x 2



03P5 x 3

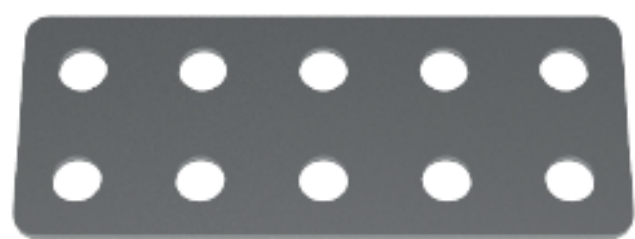

0410 x 2

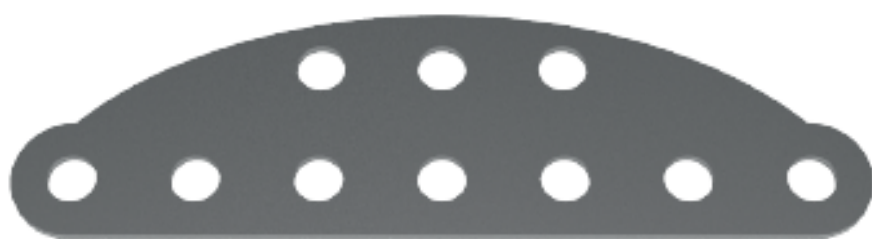

0610 x 2

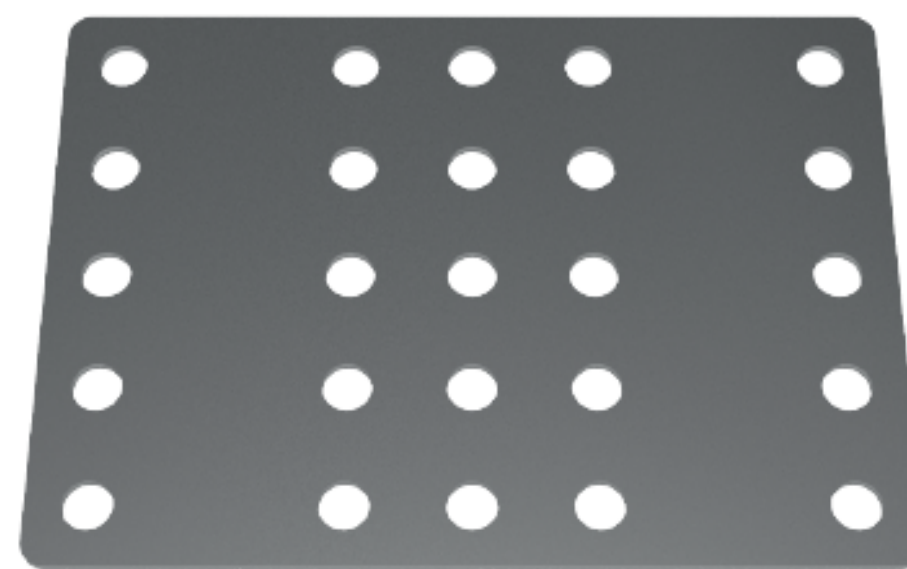

0425 x 1

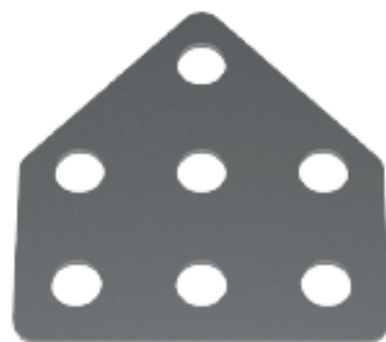

047D x 2

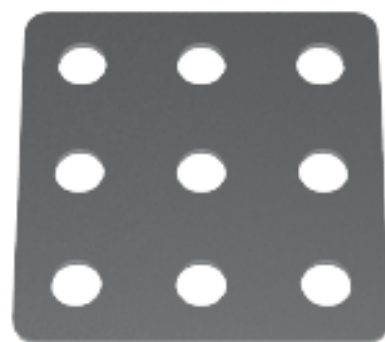

0409 x 2

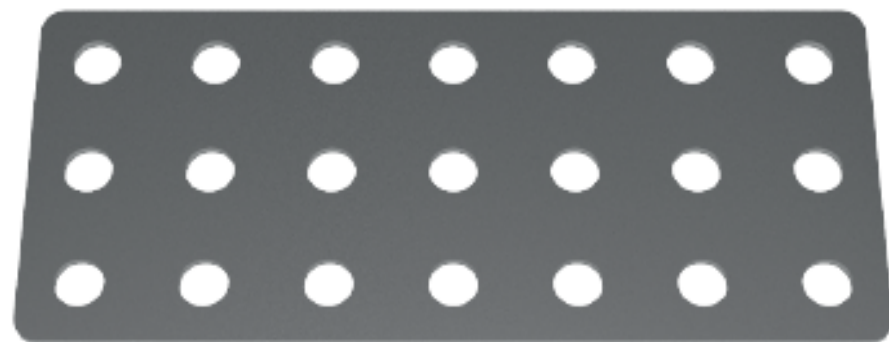

0421 x 5



0603 x 4

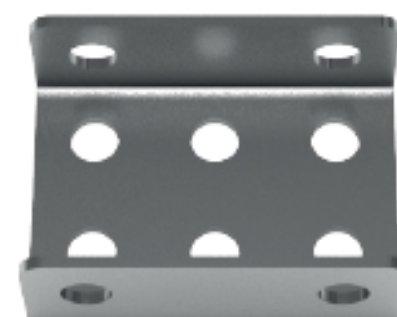

0512 x 2



0731x 1



0705 x 4



0716 x 4

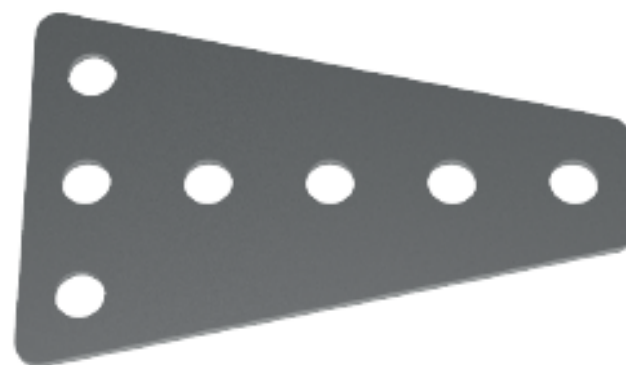

047DW x 5

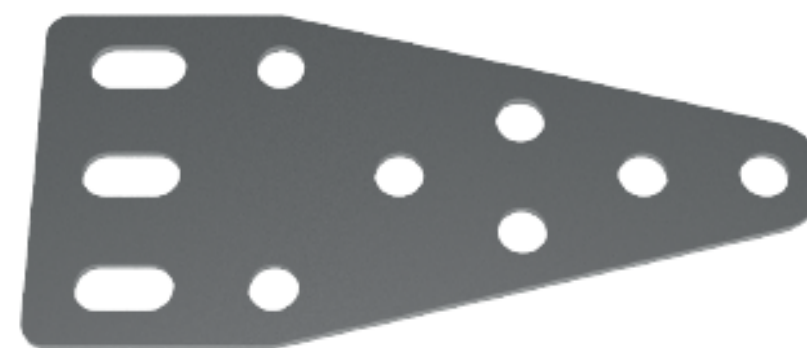

047F3 x 2



0905 x 2



0781Z x 32



0781Z x 2



0781CZ x 4



0781B x 4

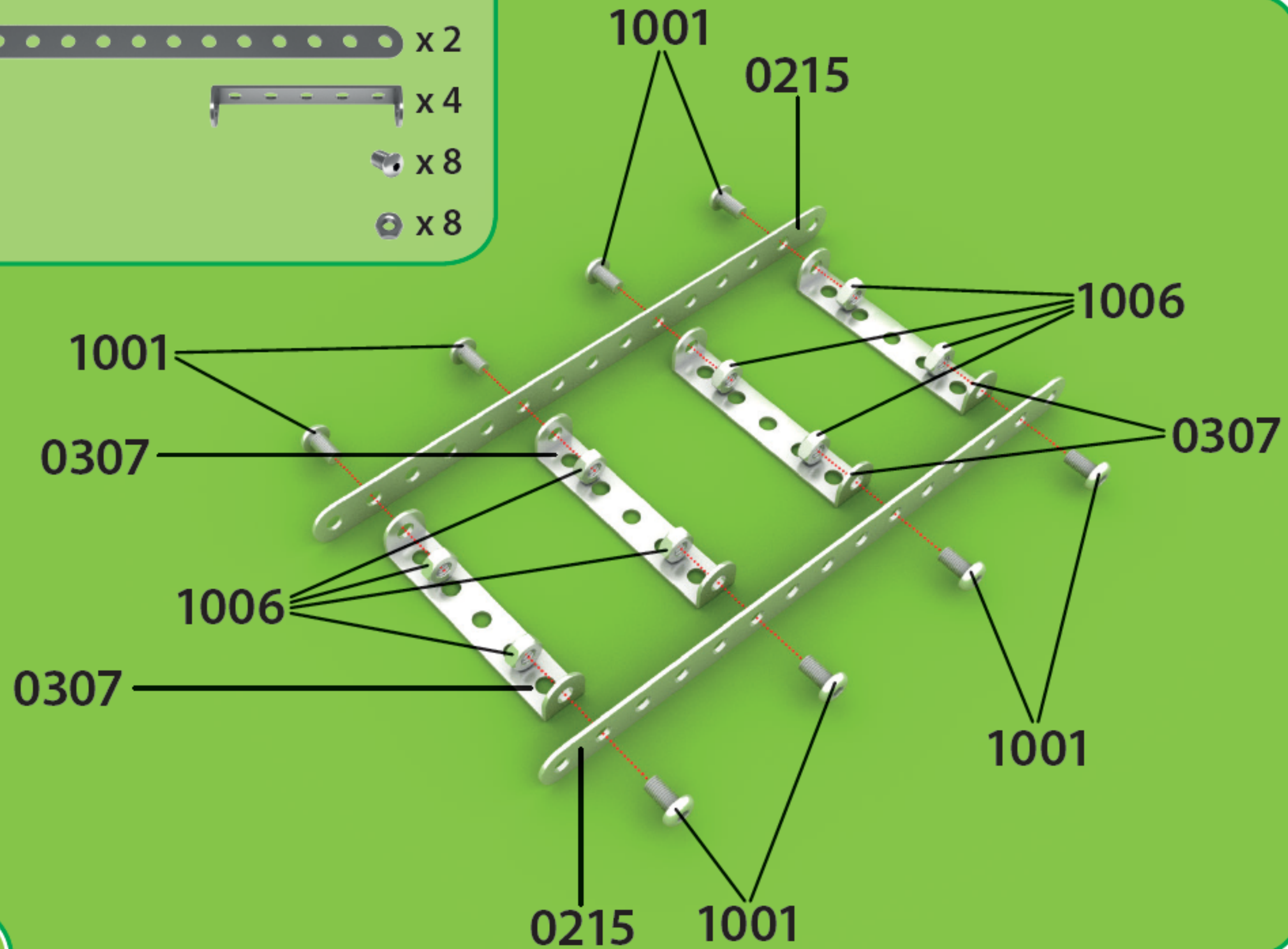
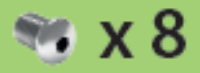

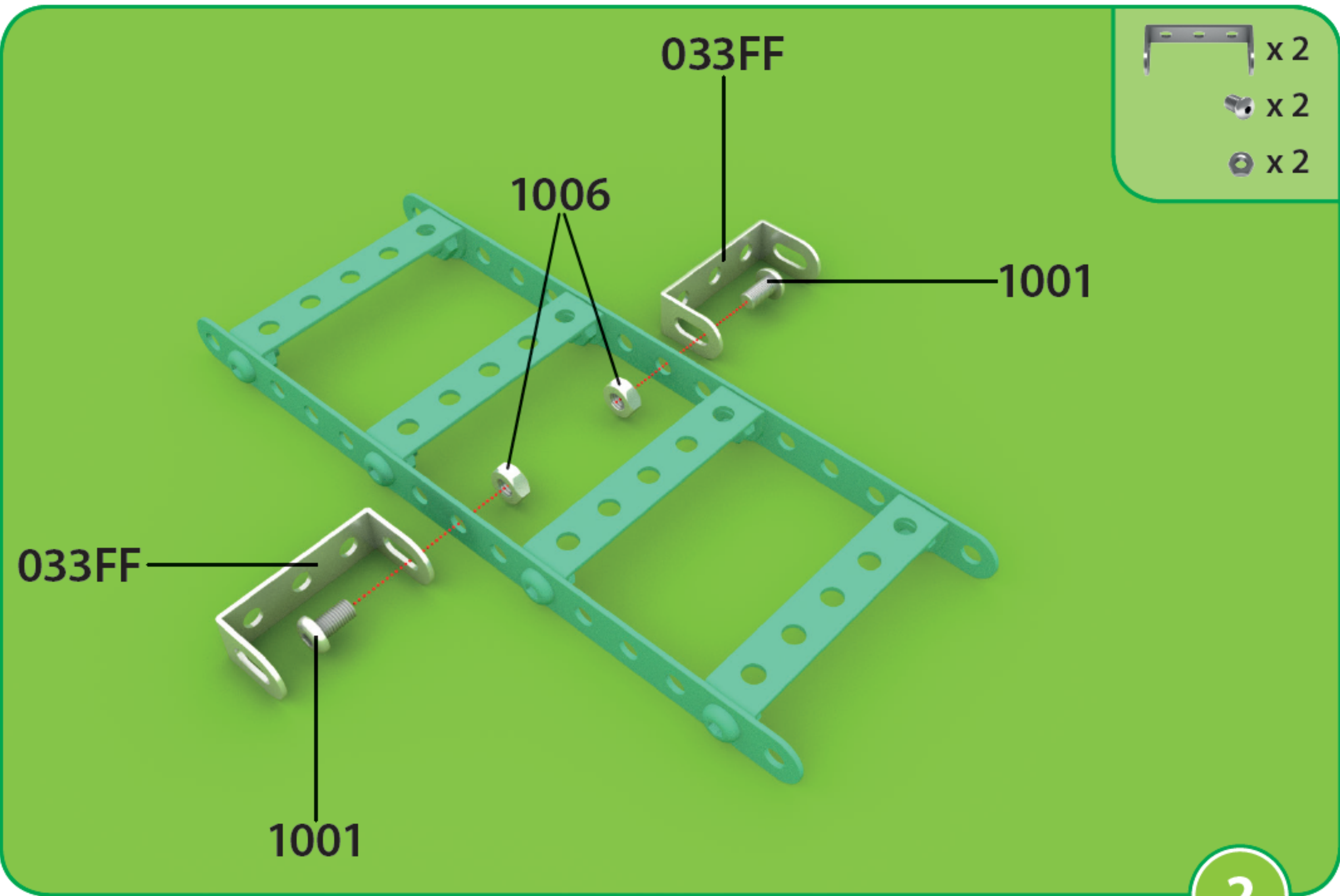



x 2



x 4







x 4

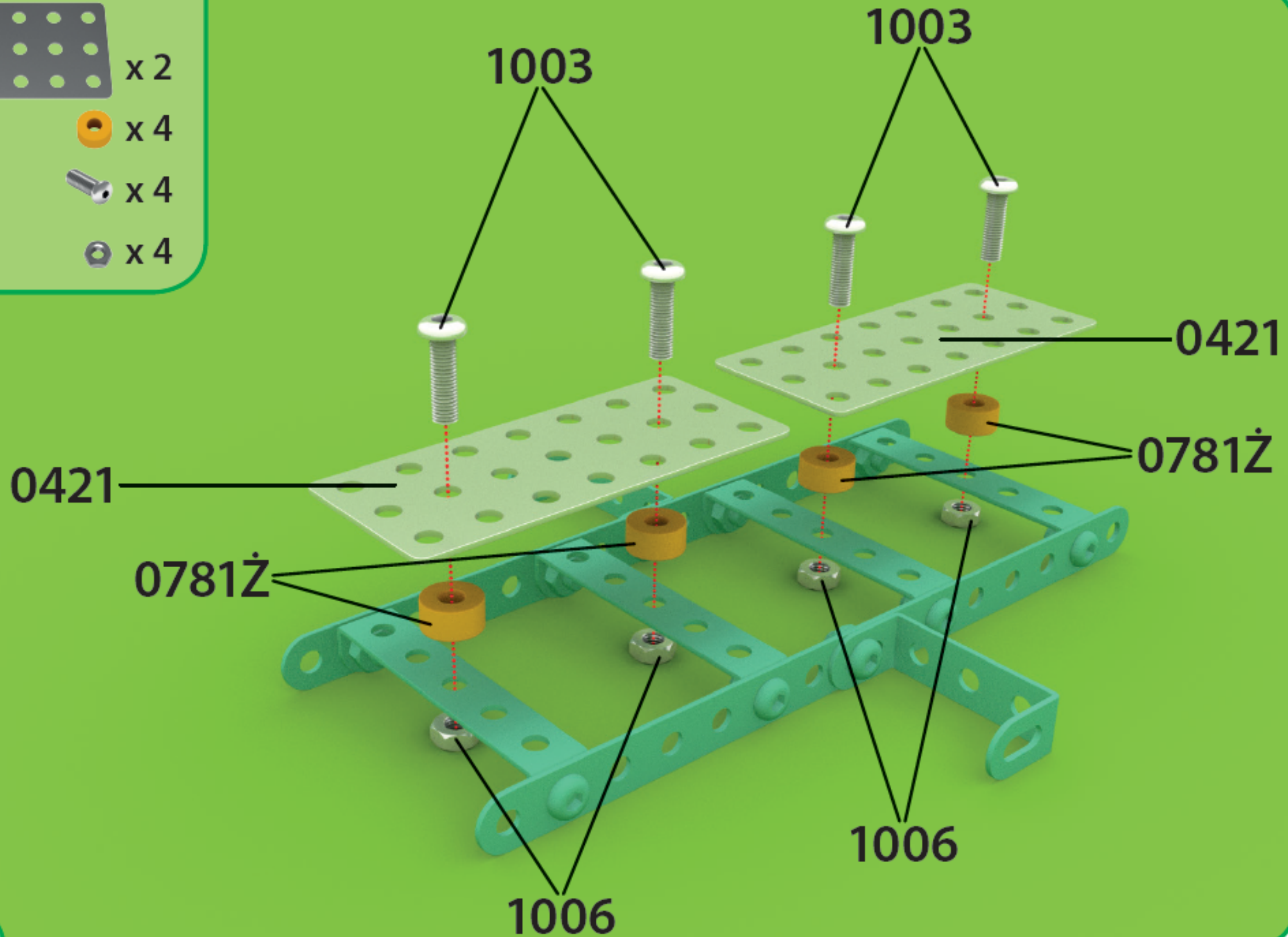

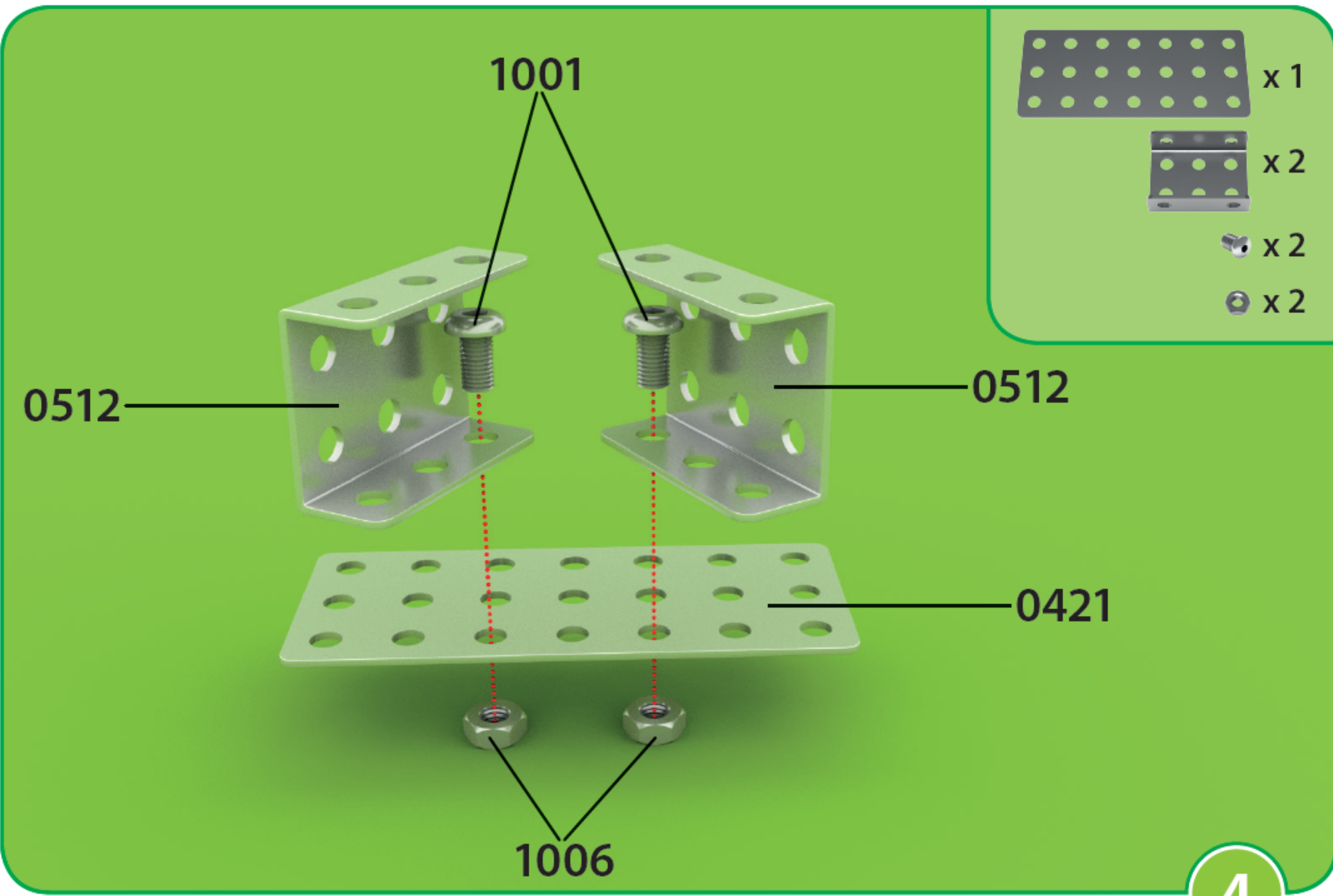
x 4







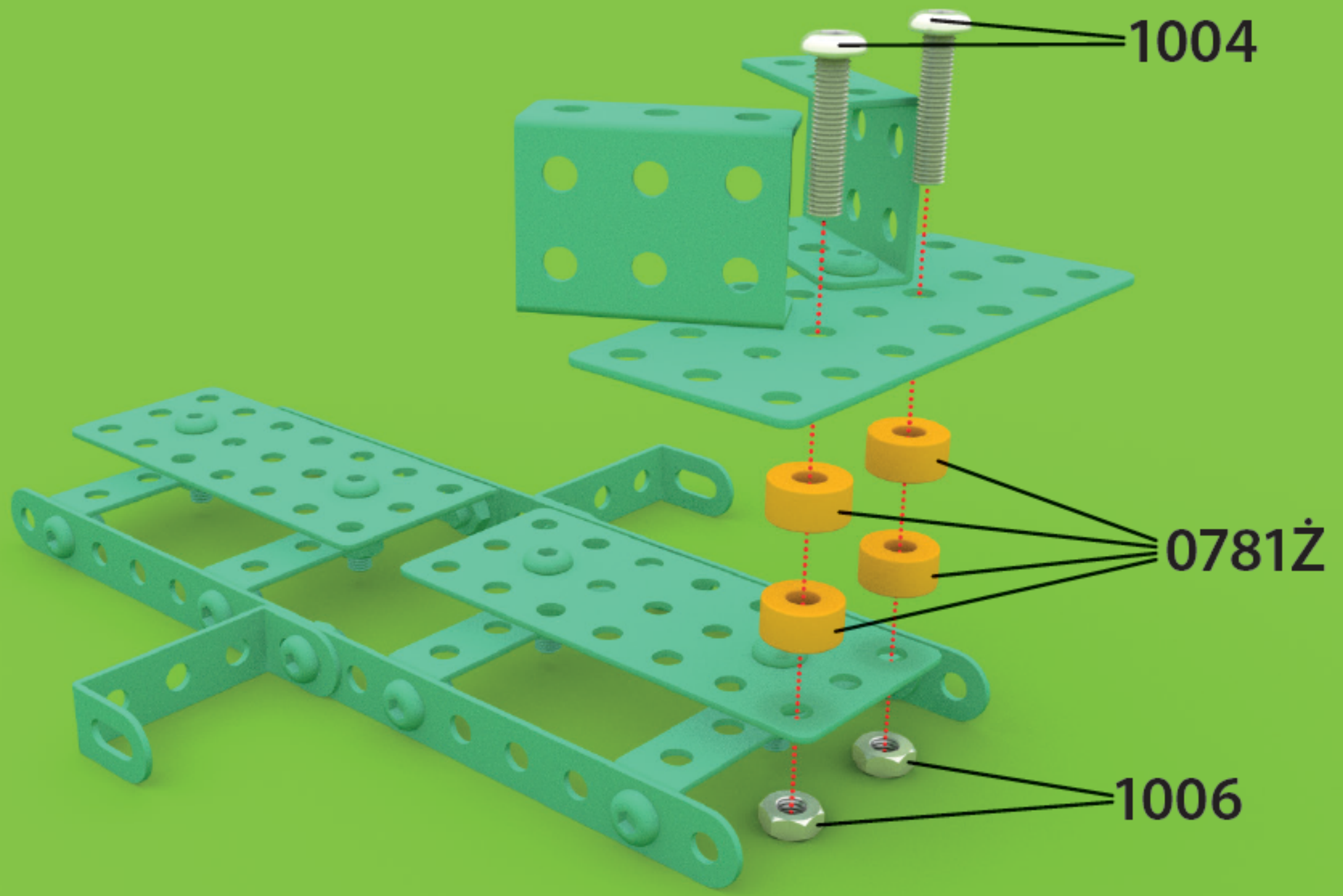

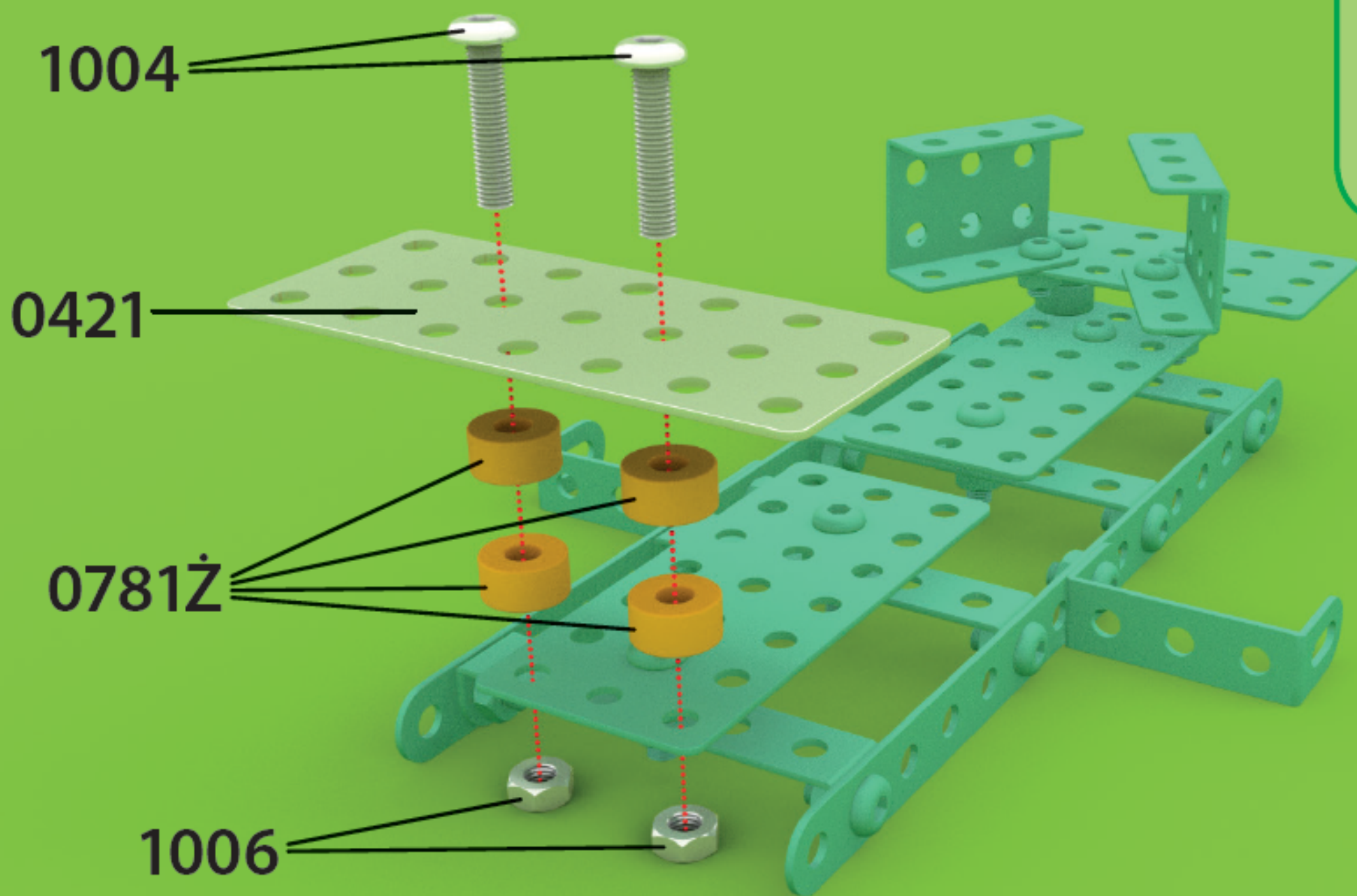





-  x 4
-  x 2
-  x 2







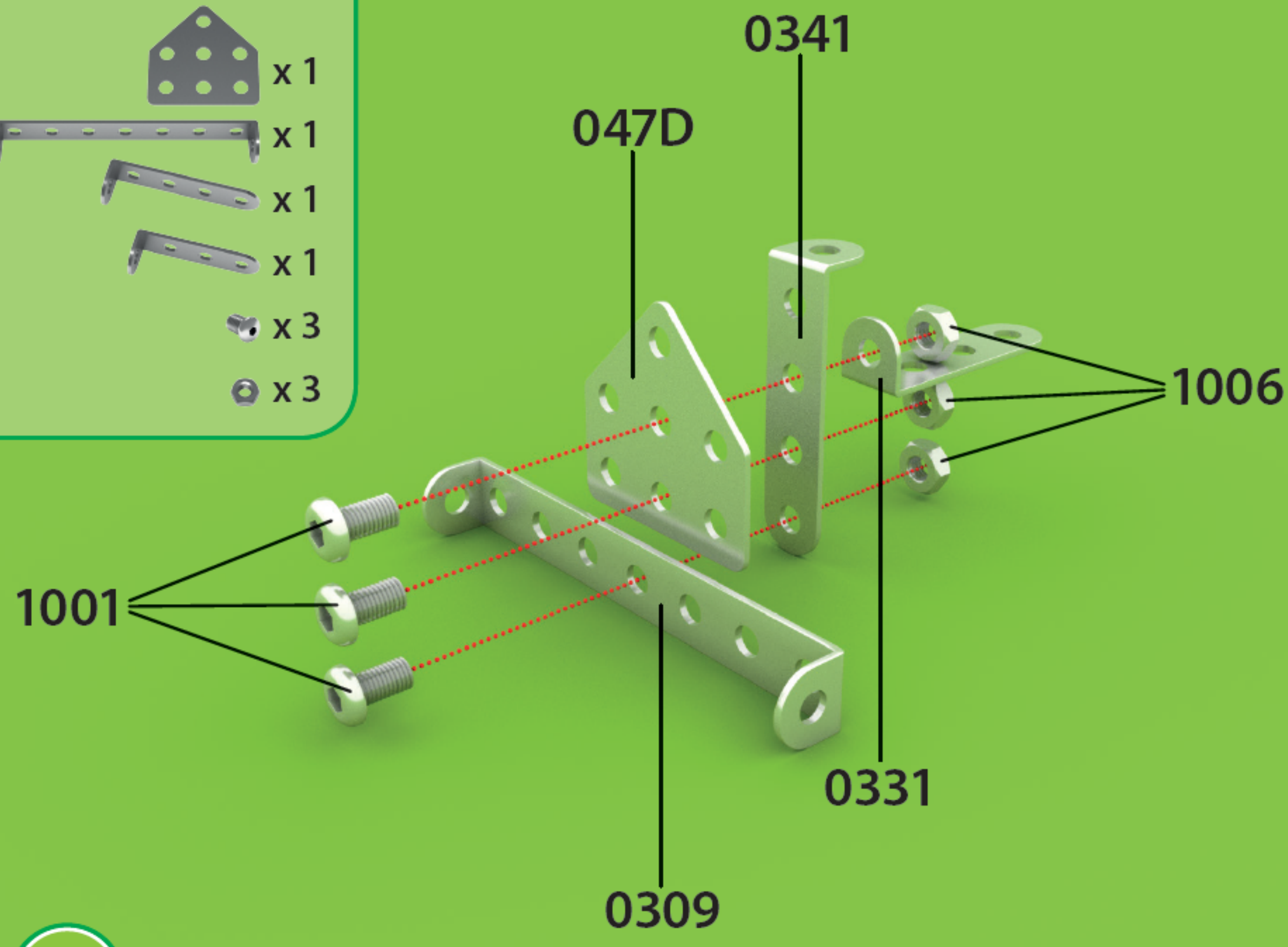

-  x 1
-  x 4
-  x 2
-  x 2

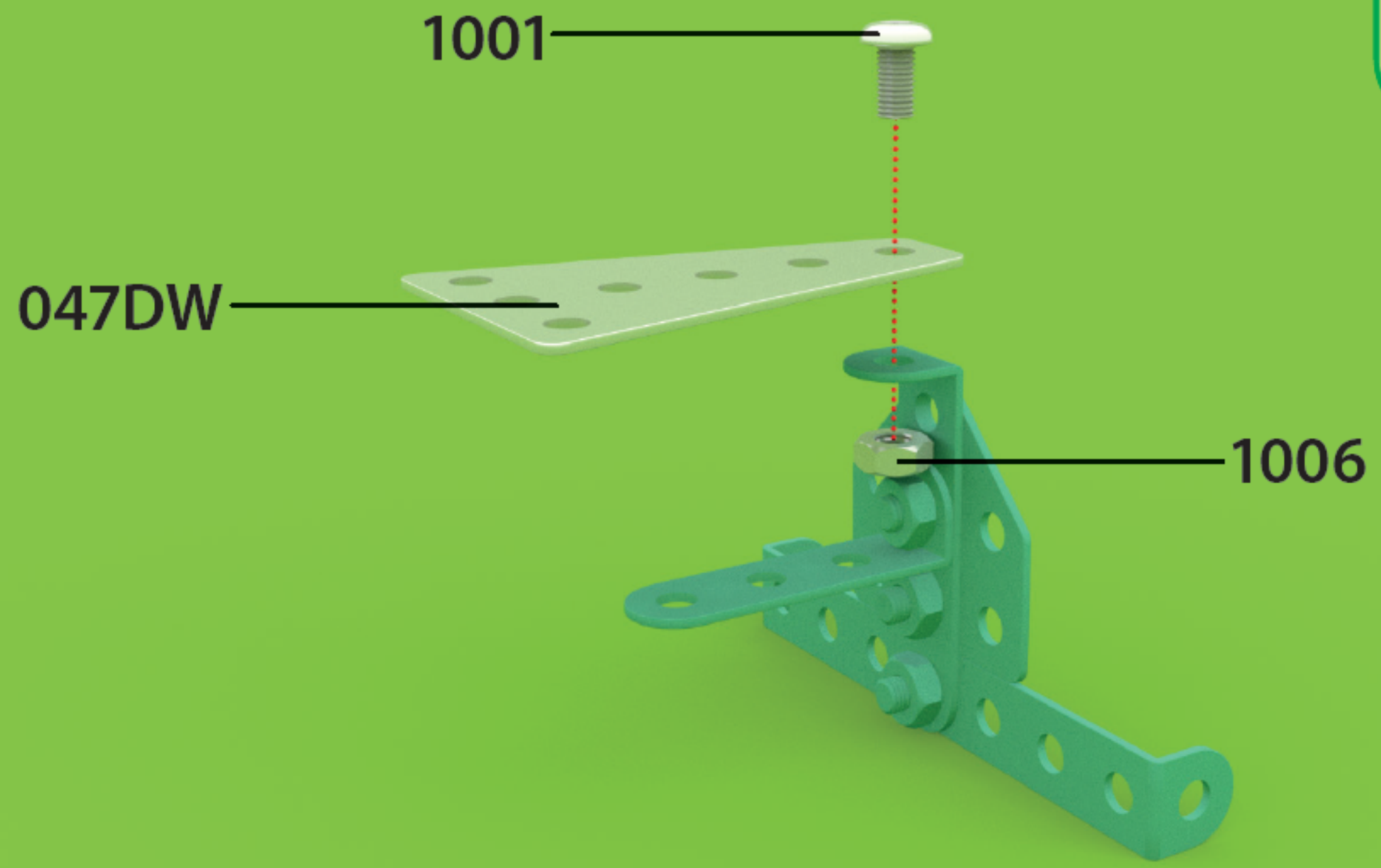
-  x 1
-  x 1
-  x 1
-  x 1
-  x 3
-  x 3









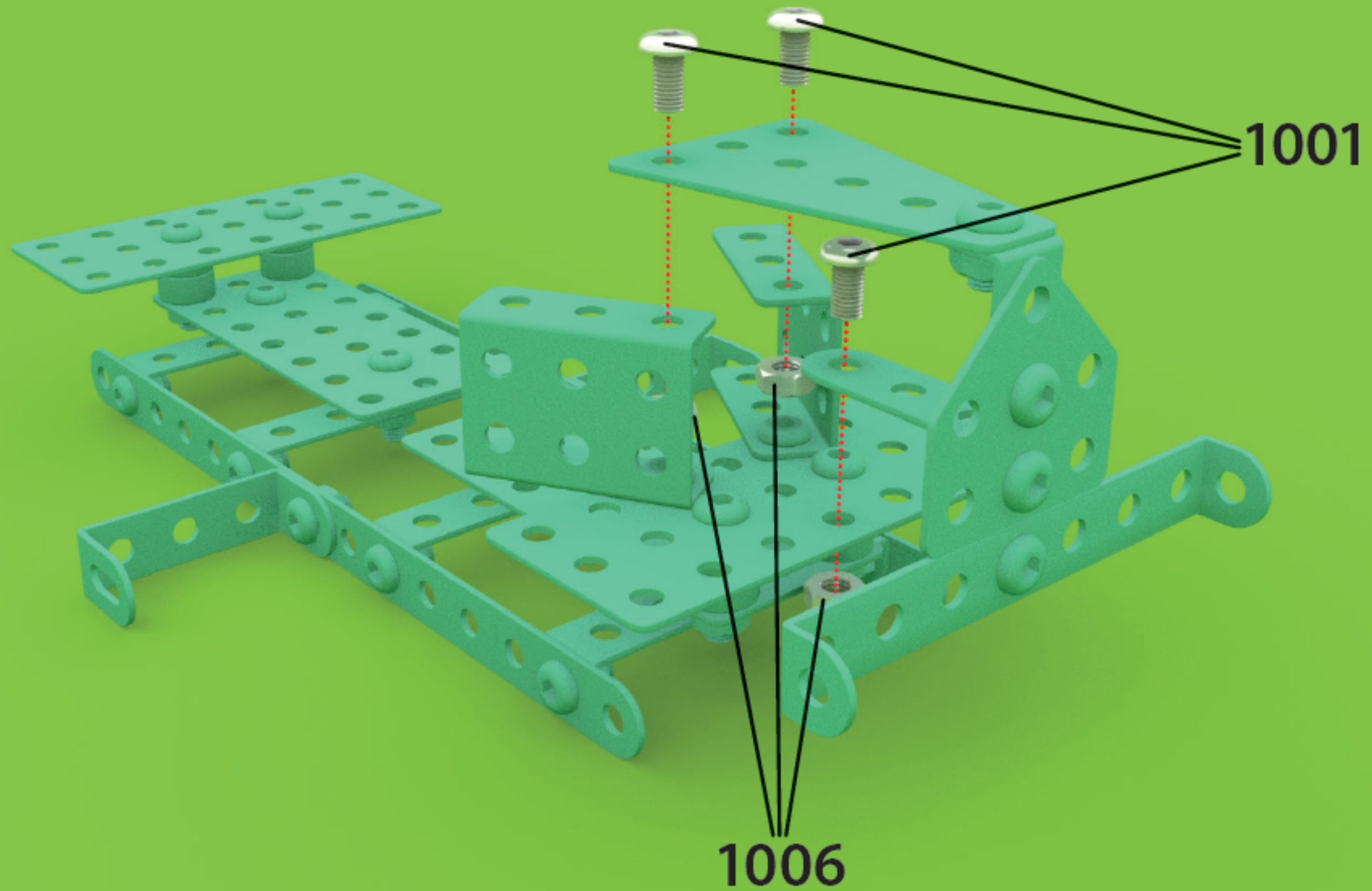

-  x 1
-  x 1
-  x 1

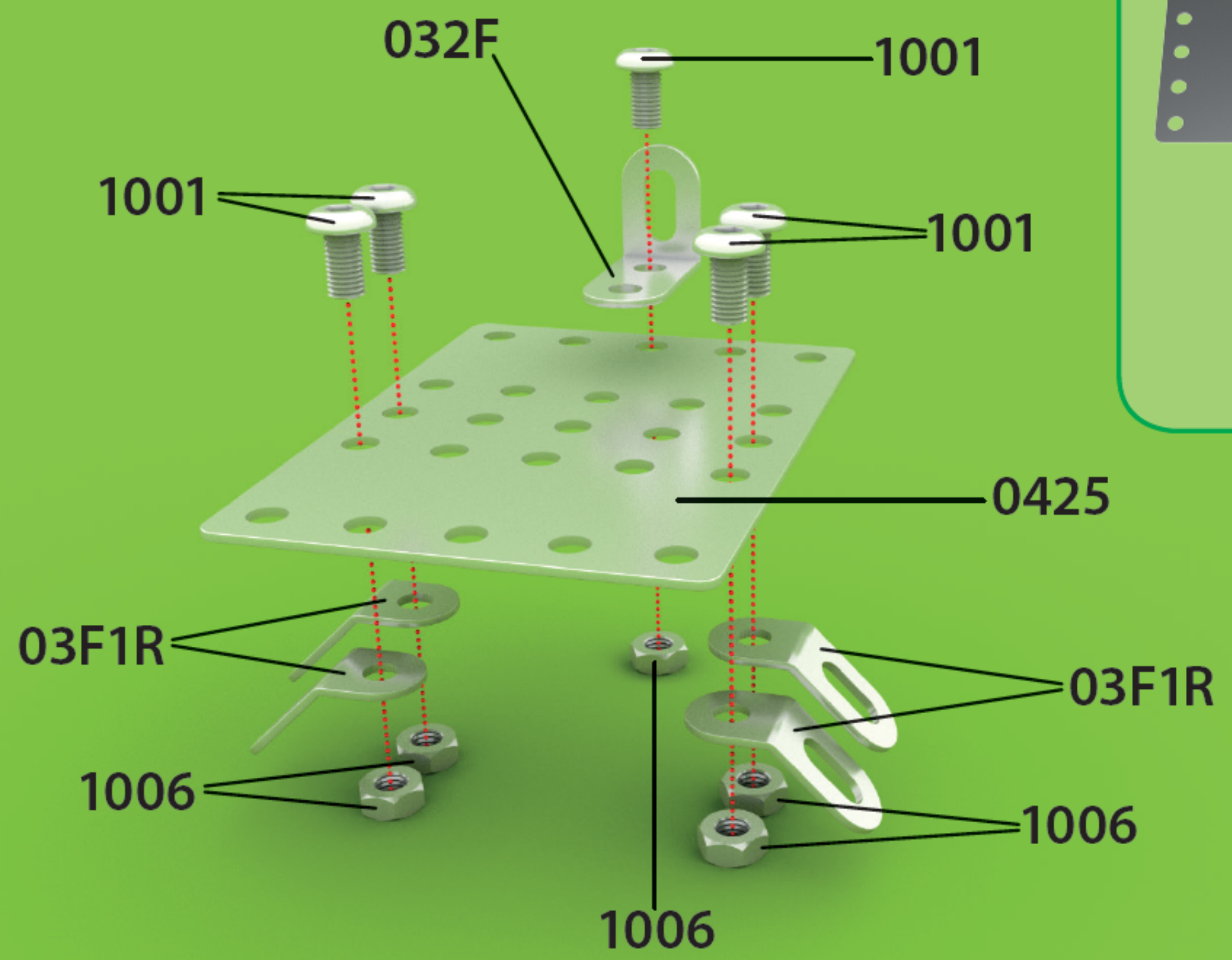
 x 3

 x 3





-  x 1
-  x 1
-  x 4
-  x 5
-  x 5



x 2



x 4



x 4

1001

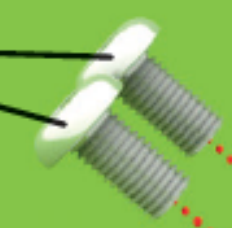

0610

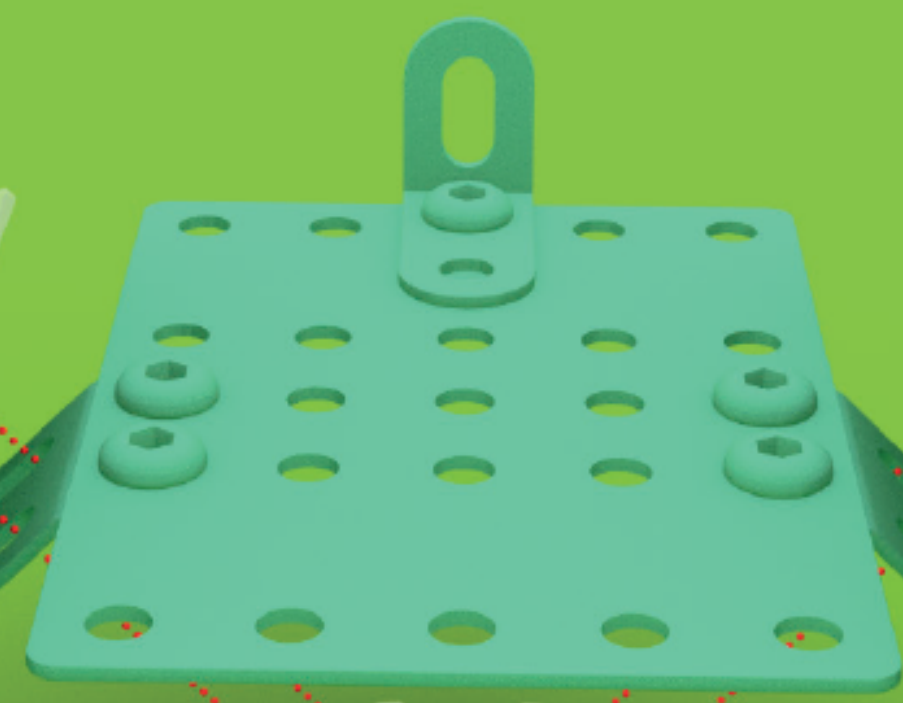
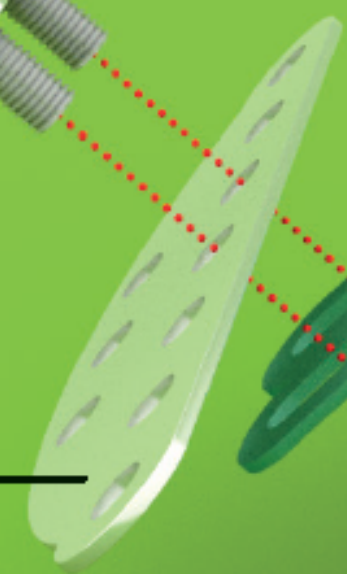

1001



0610

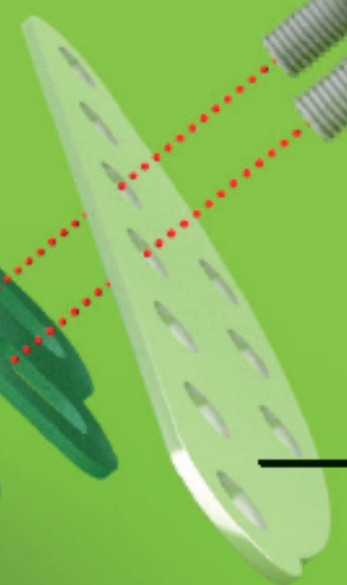



1006

1003

0731

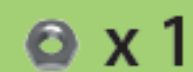
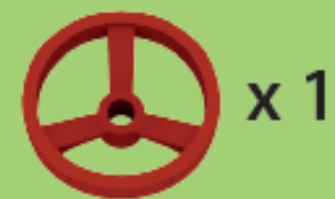
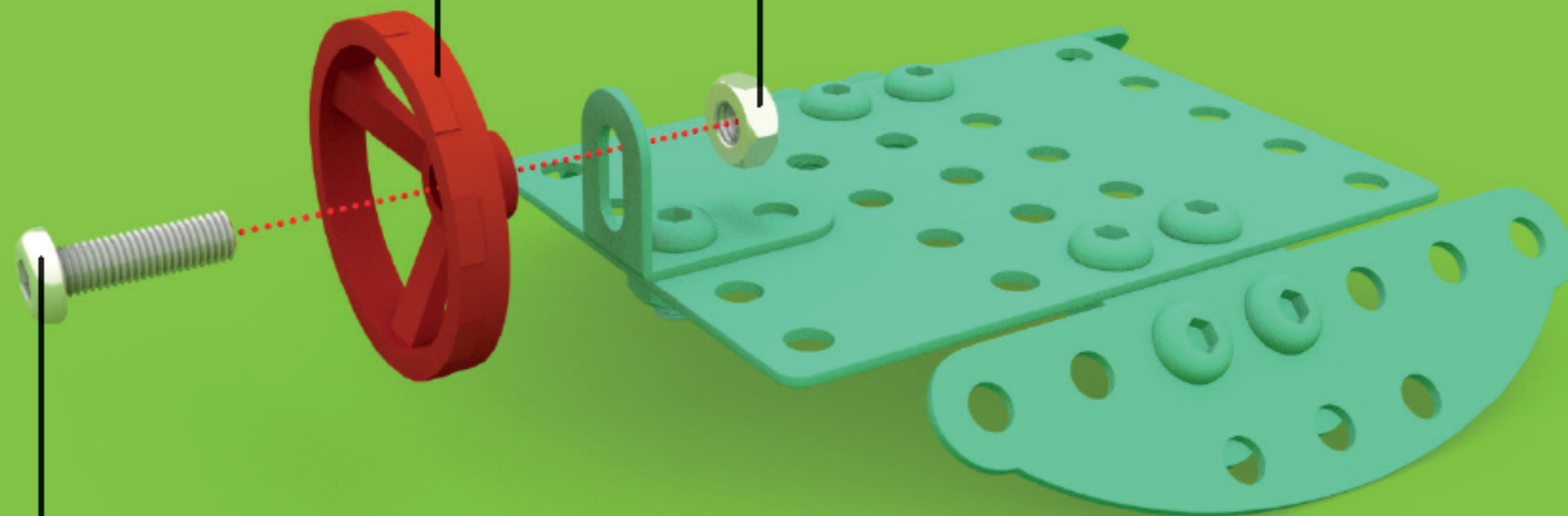
1006



 x 2

 x 2

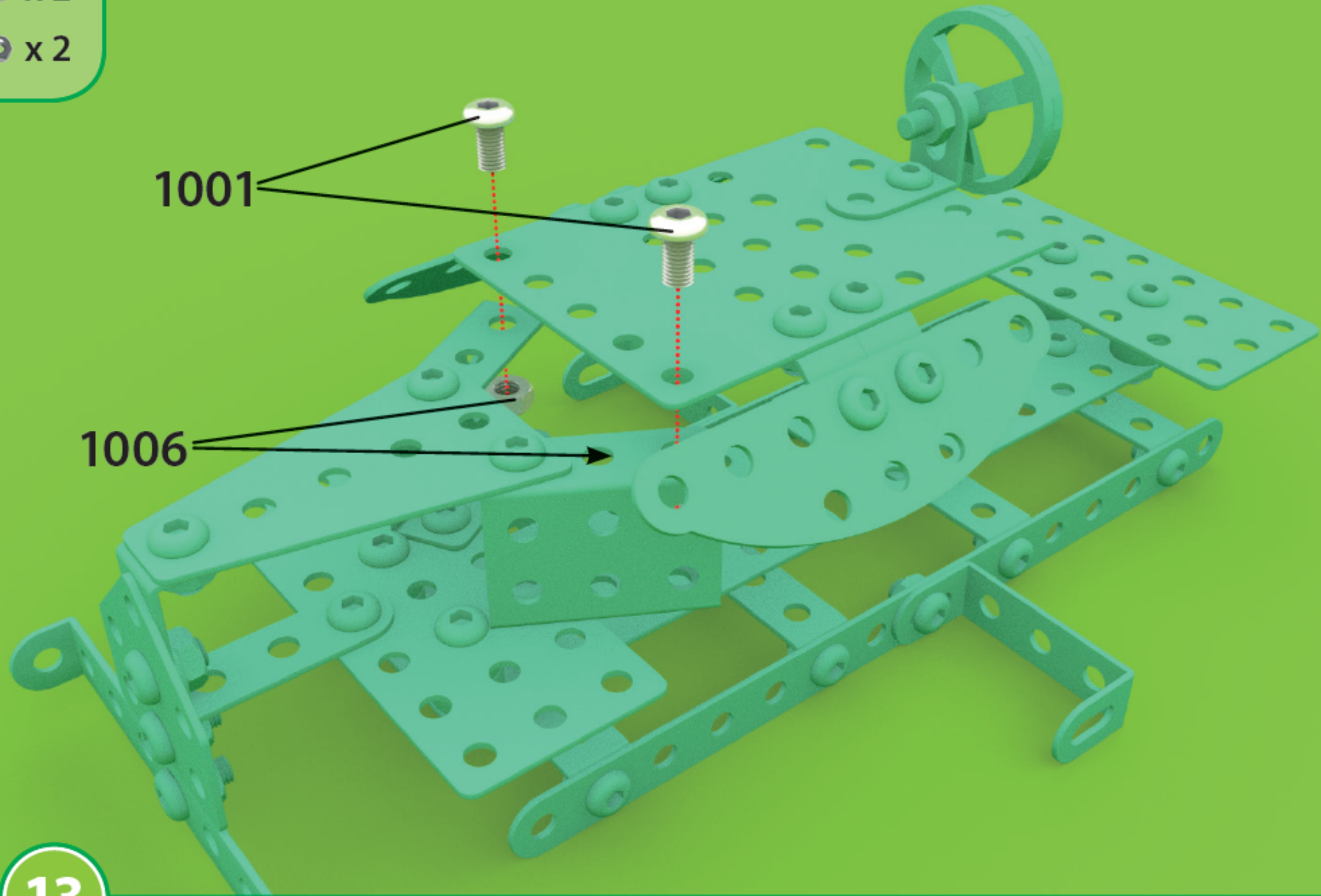

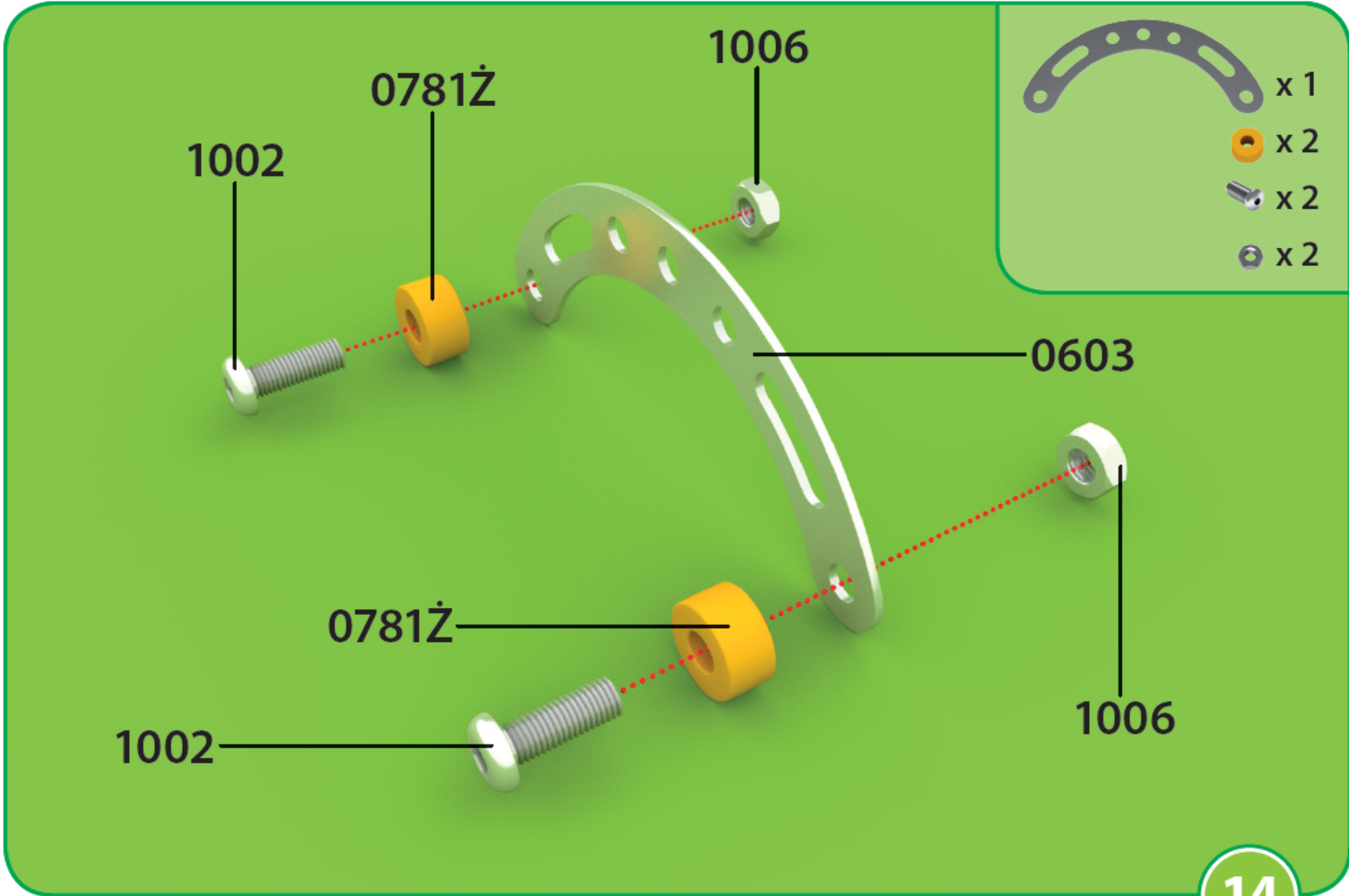



x 2

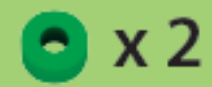

x 2

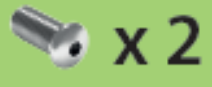



x 2

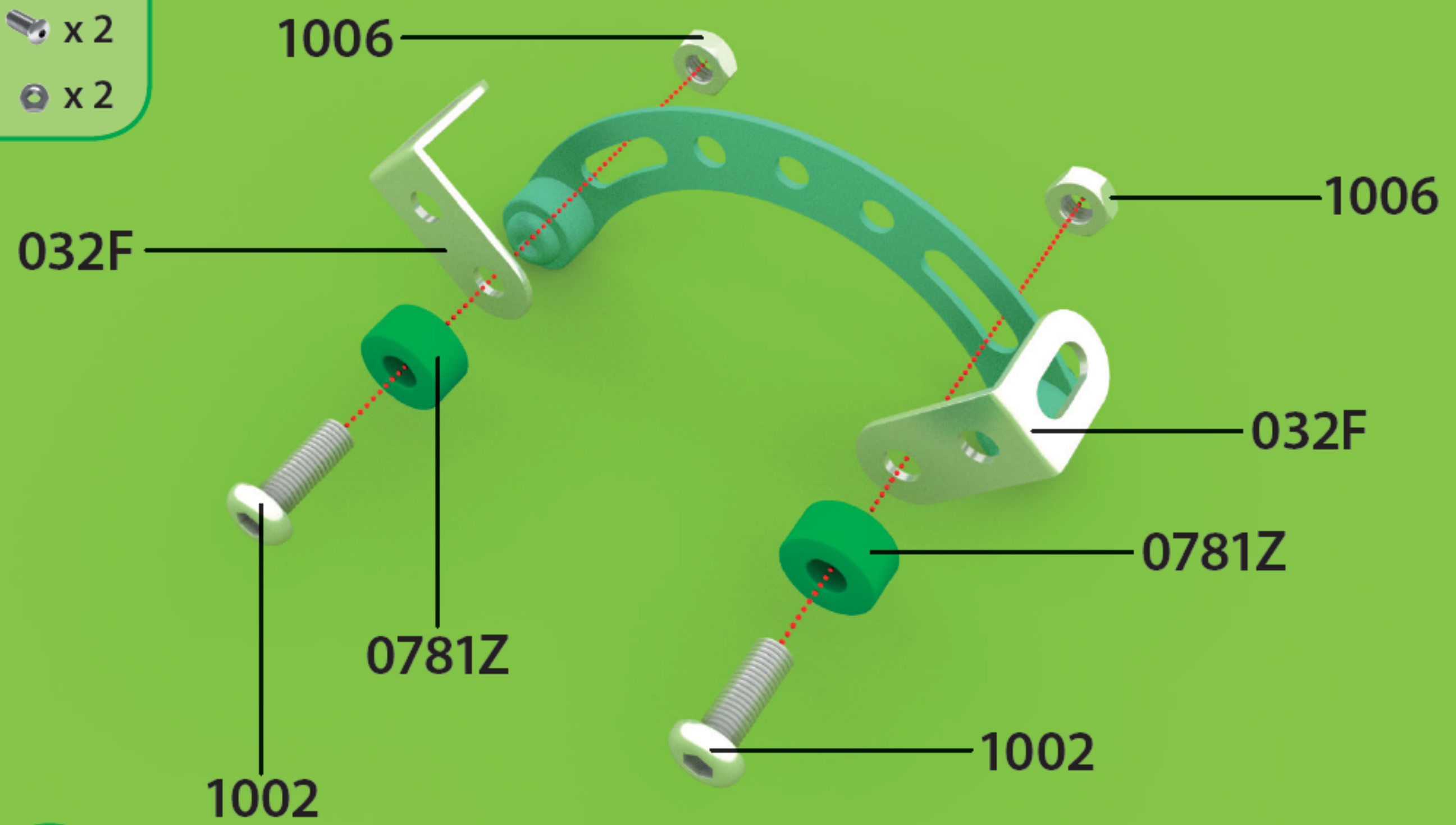

x 2

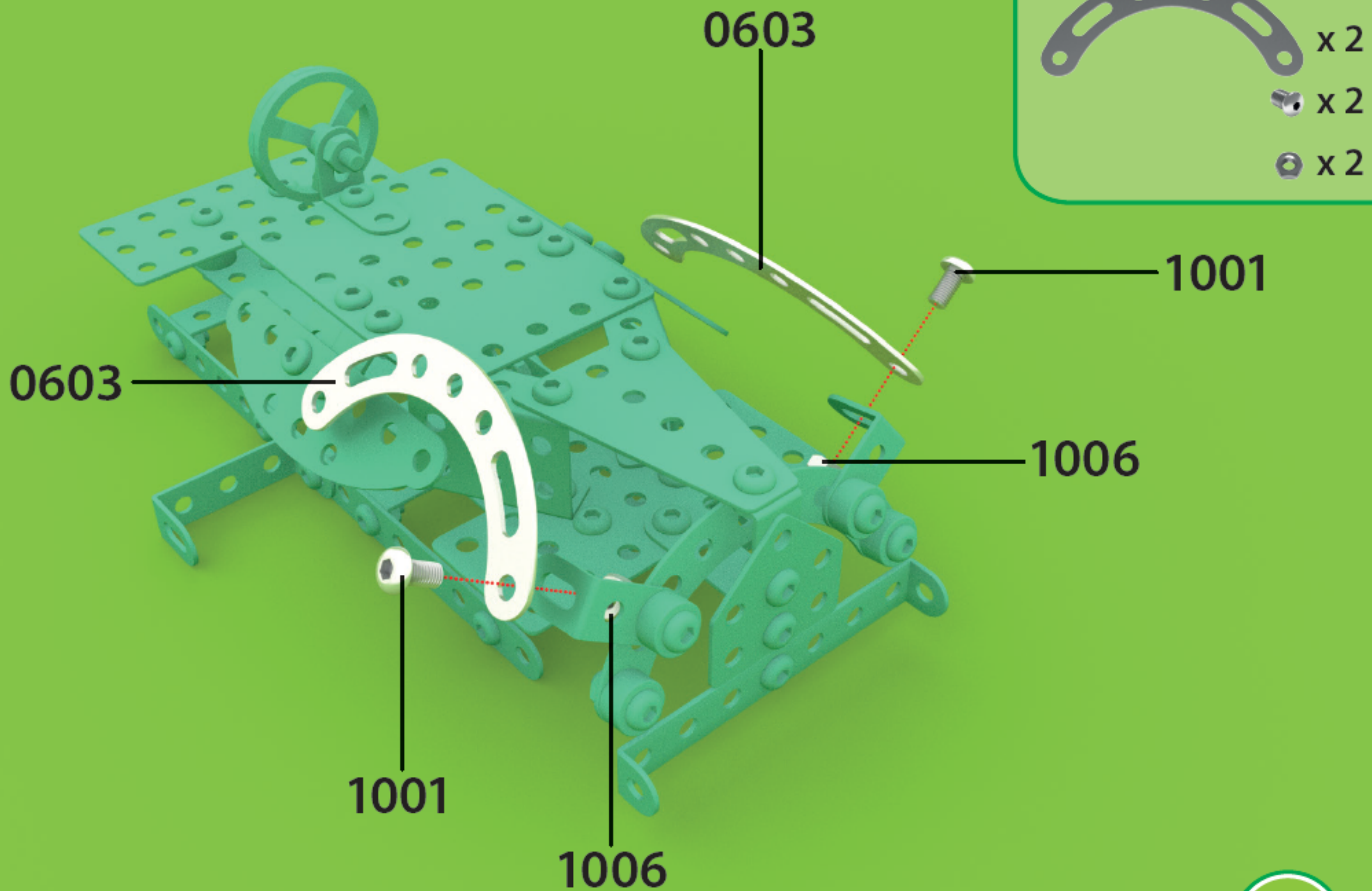



 x 2

 x 2

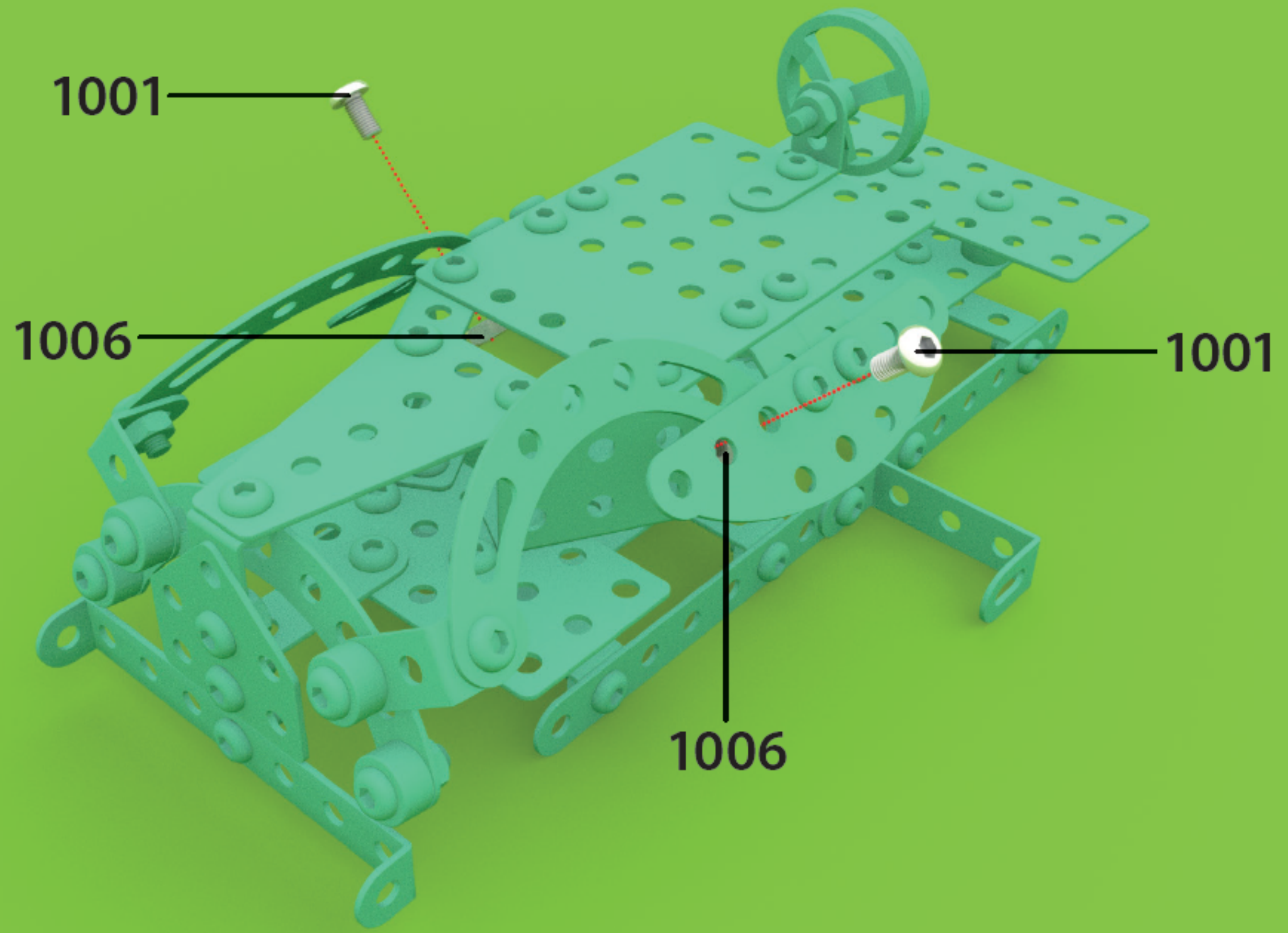

1006



03F1R

047DW

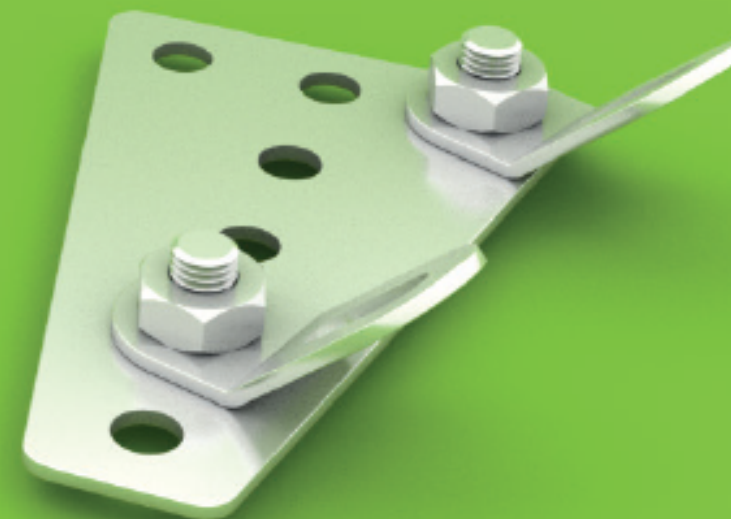

1001

-  x 2
-  x 4
-  x 4
-  x 4



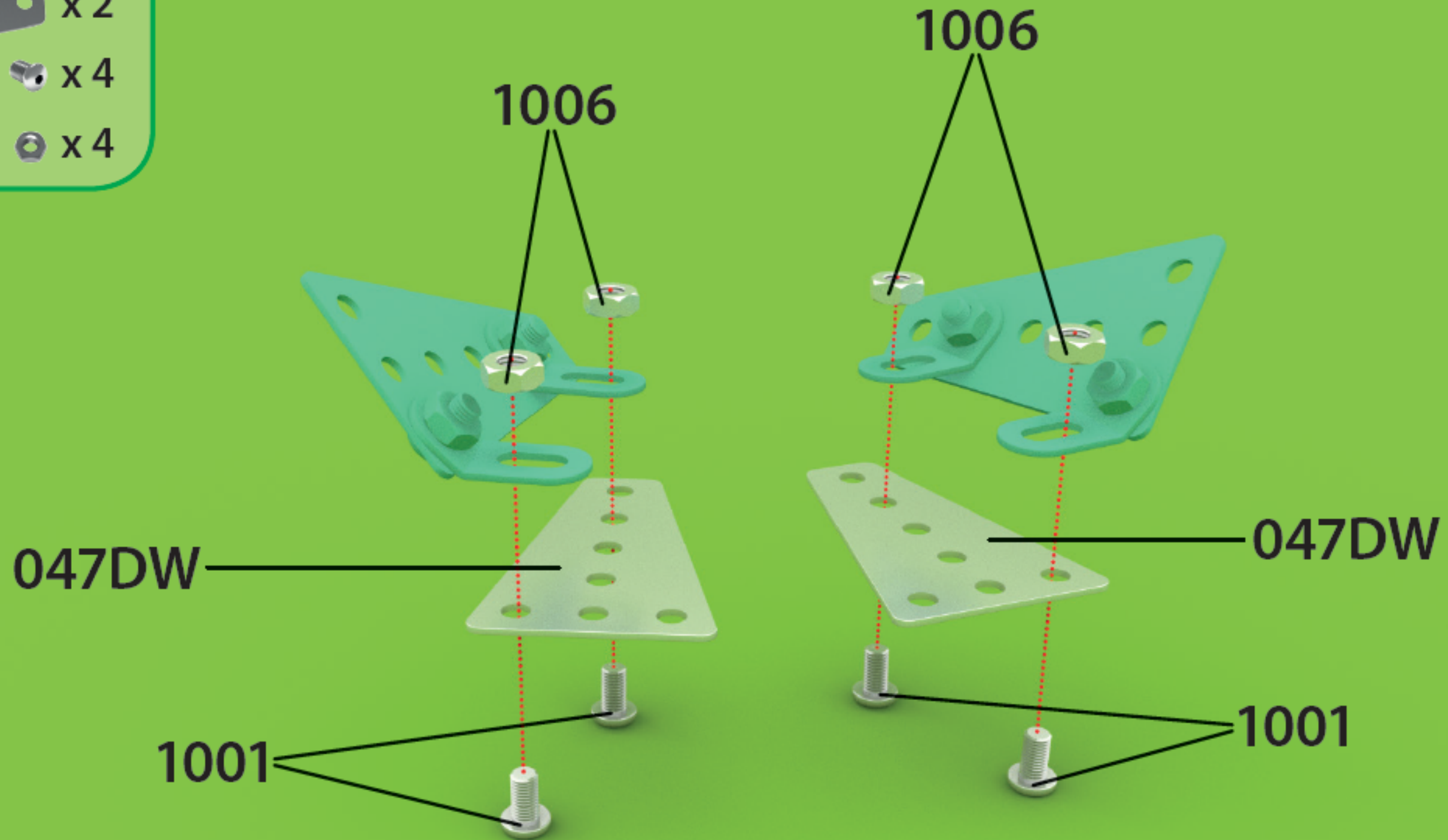

-  x 2
-  x 4
-  x 4



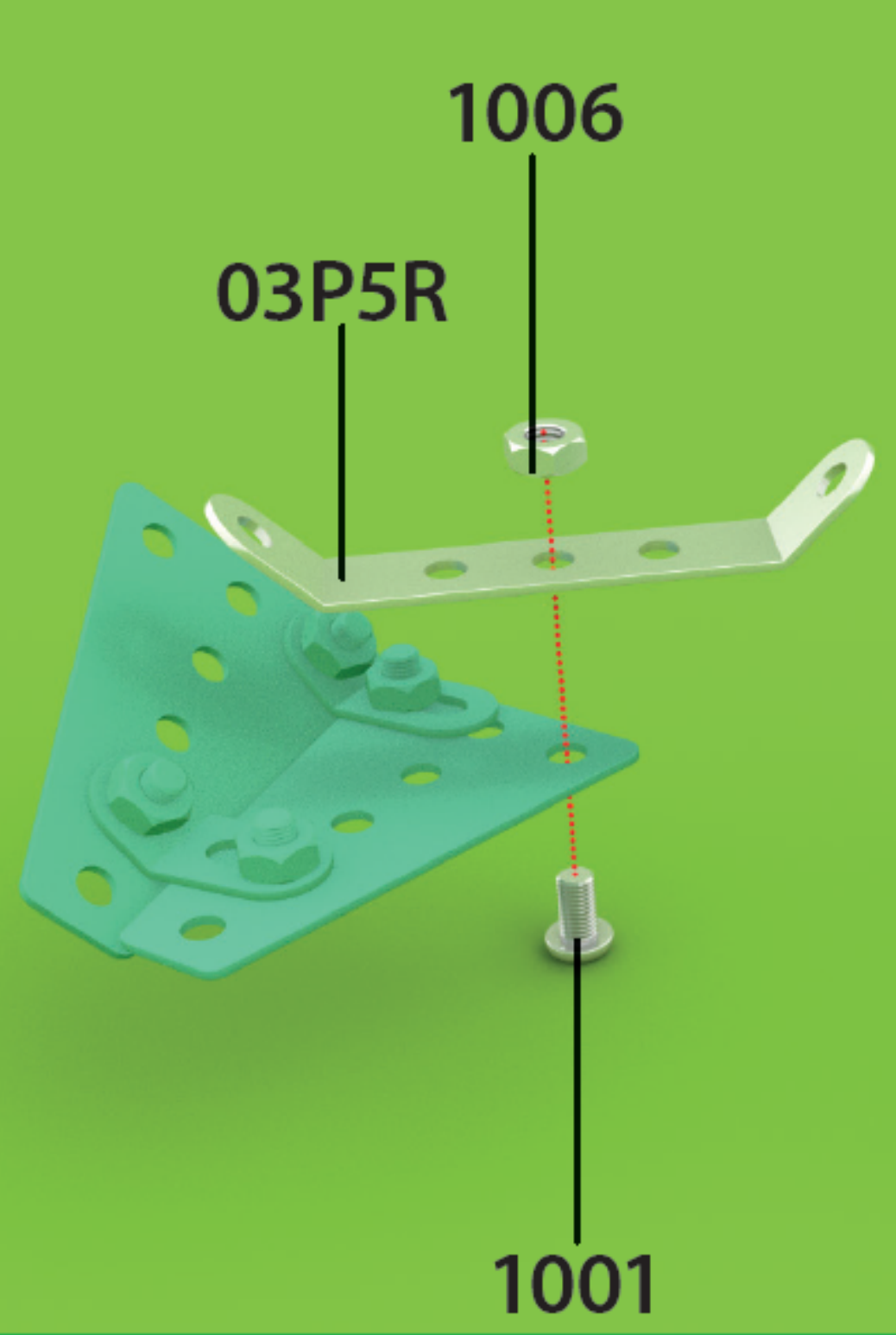

-  x 2
-  x 2
-  x 2

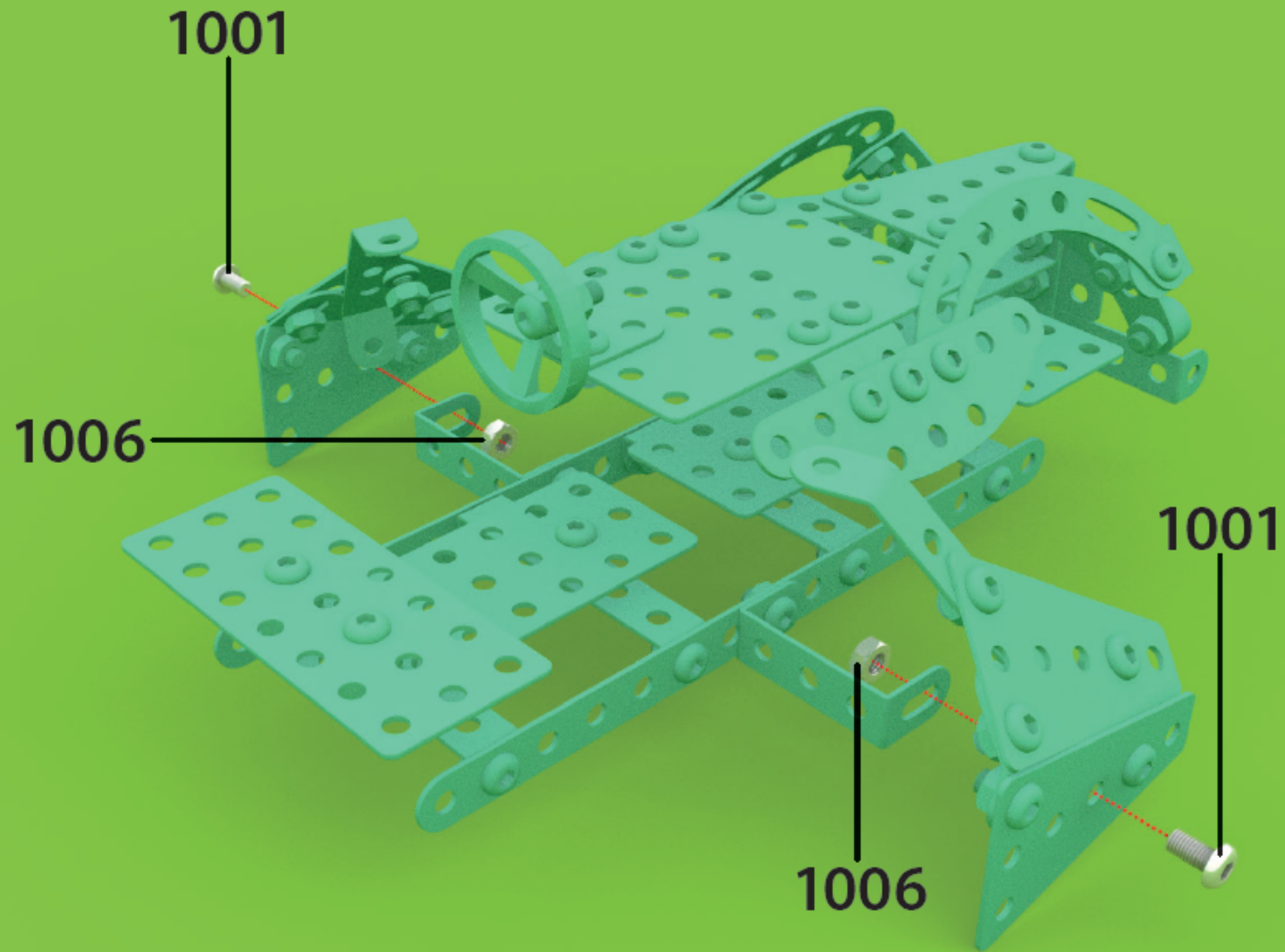

 x 2

 x 2



 x 2

 x 2

1001

1001

1006

1006

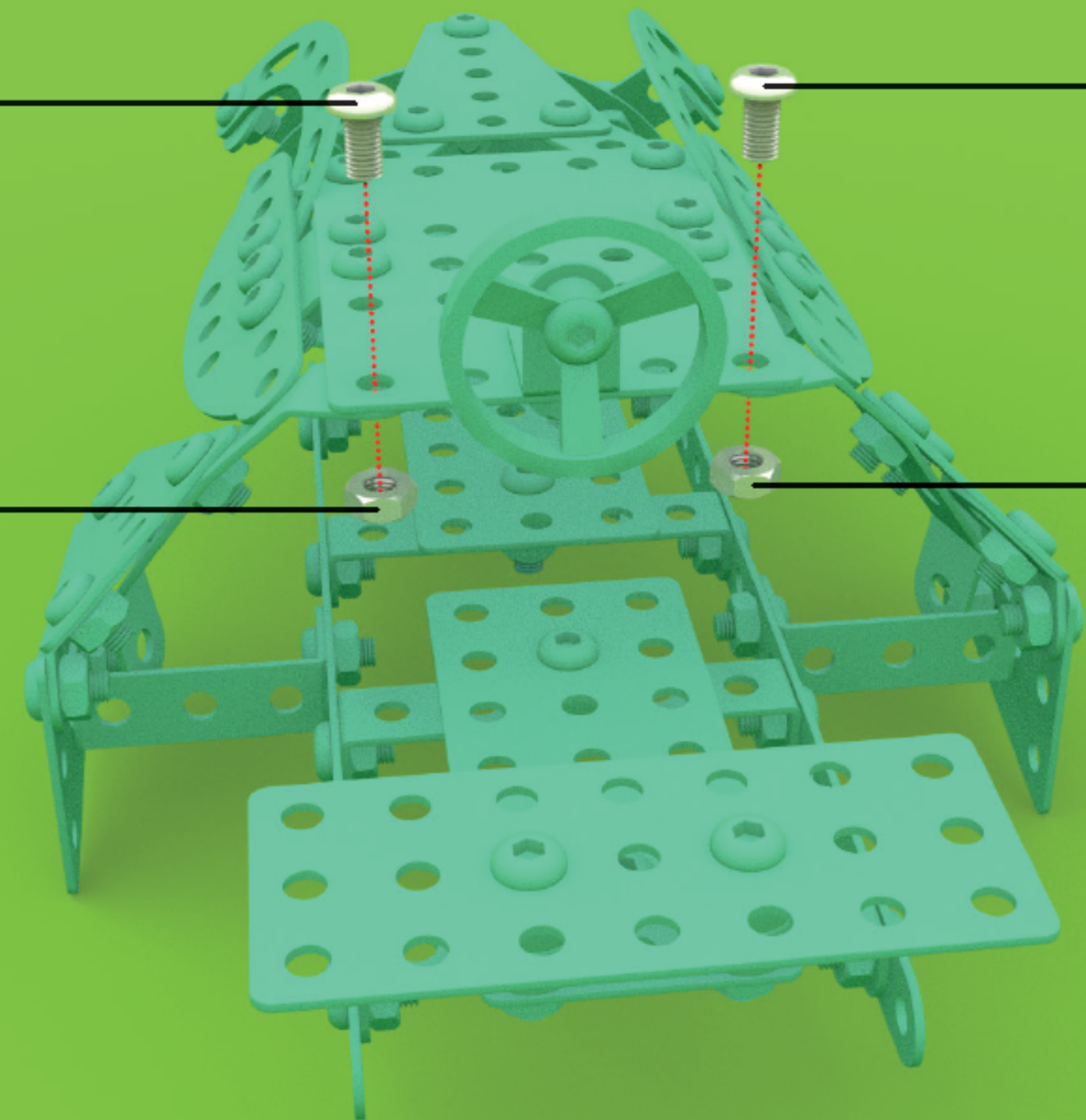



x 1



x 2



x 2



x 2

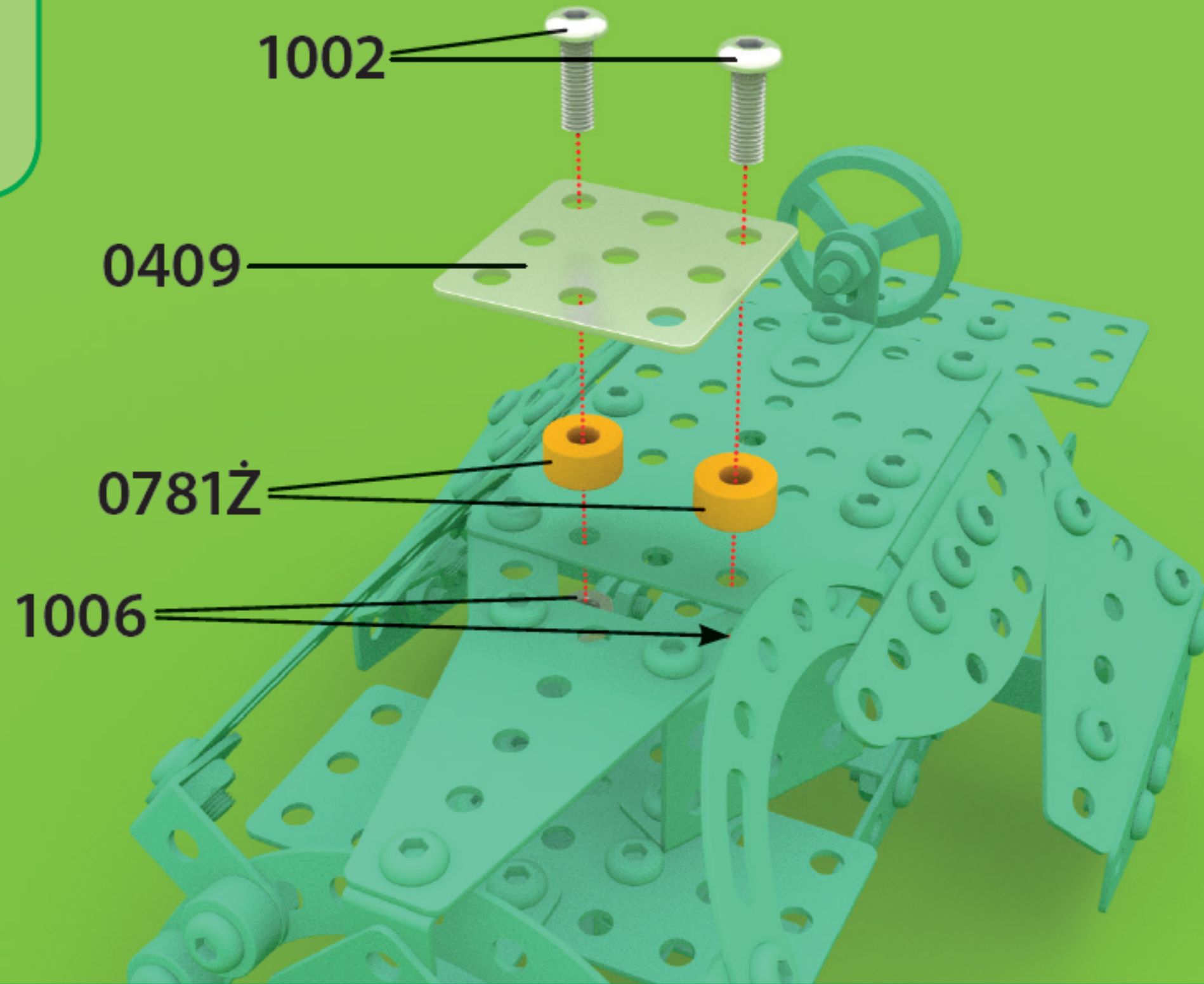

1002

0409

0781Z

1006

 x 2

 x 2

 x 2

 x 2

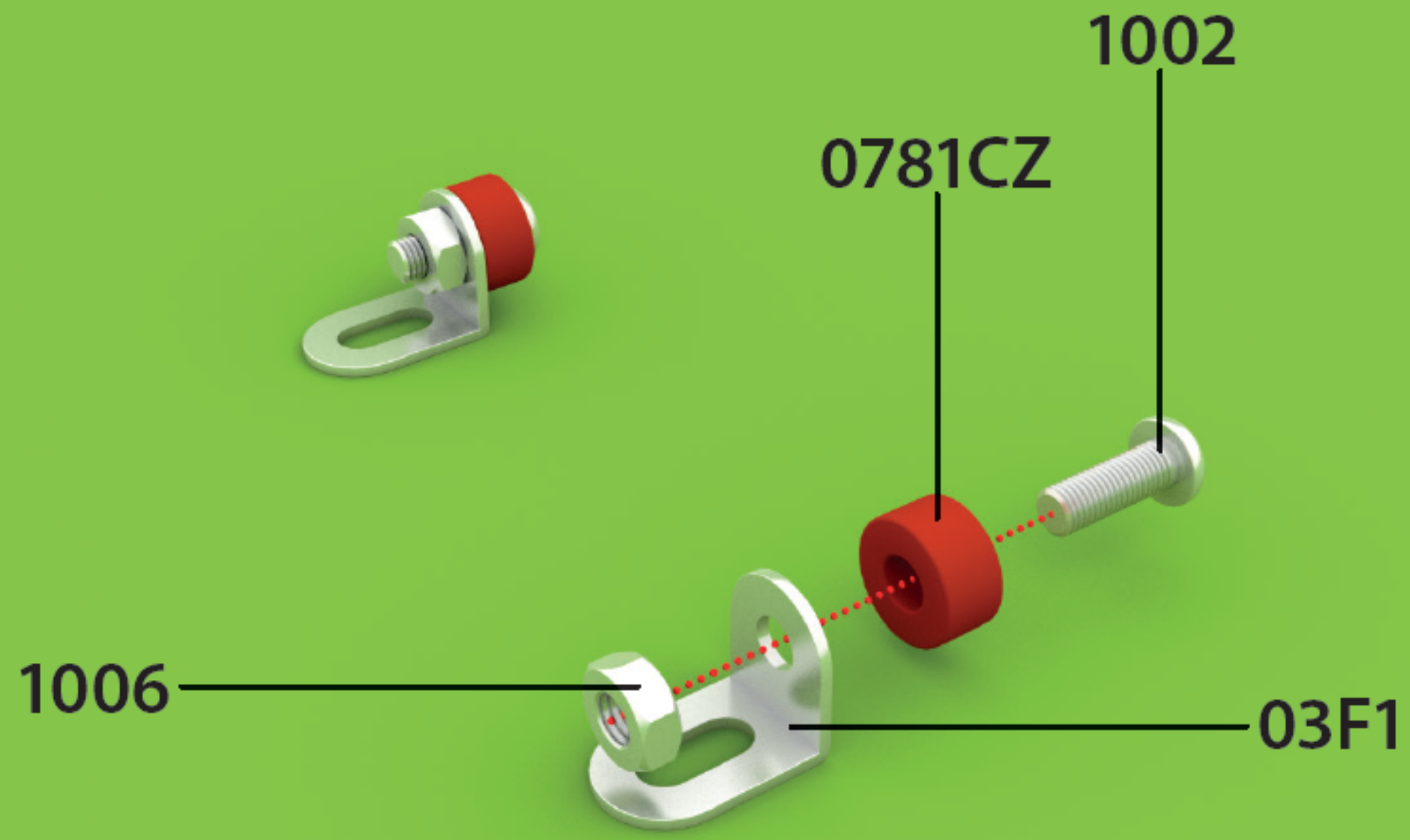



x 2



x 1





x 4



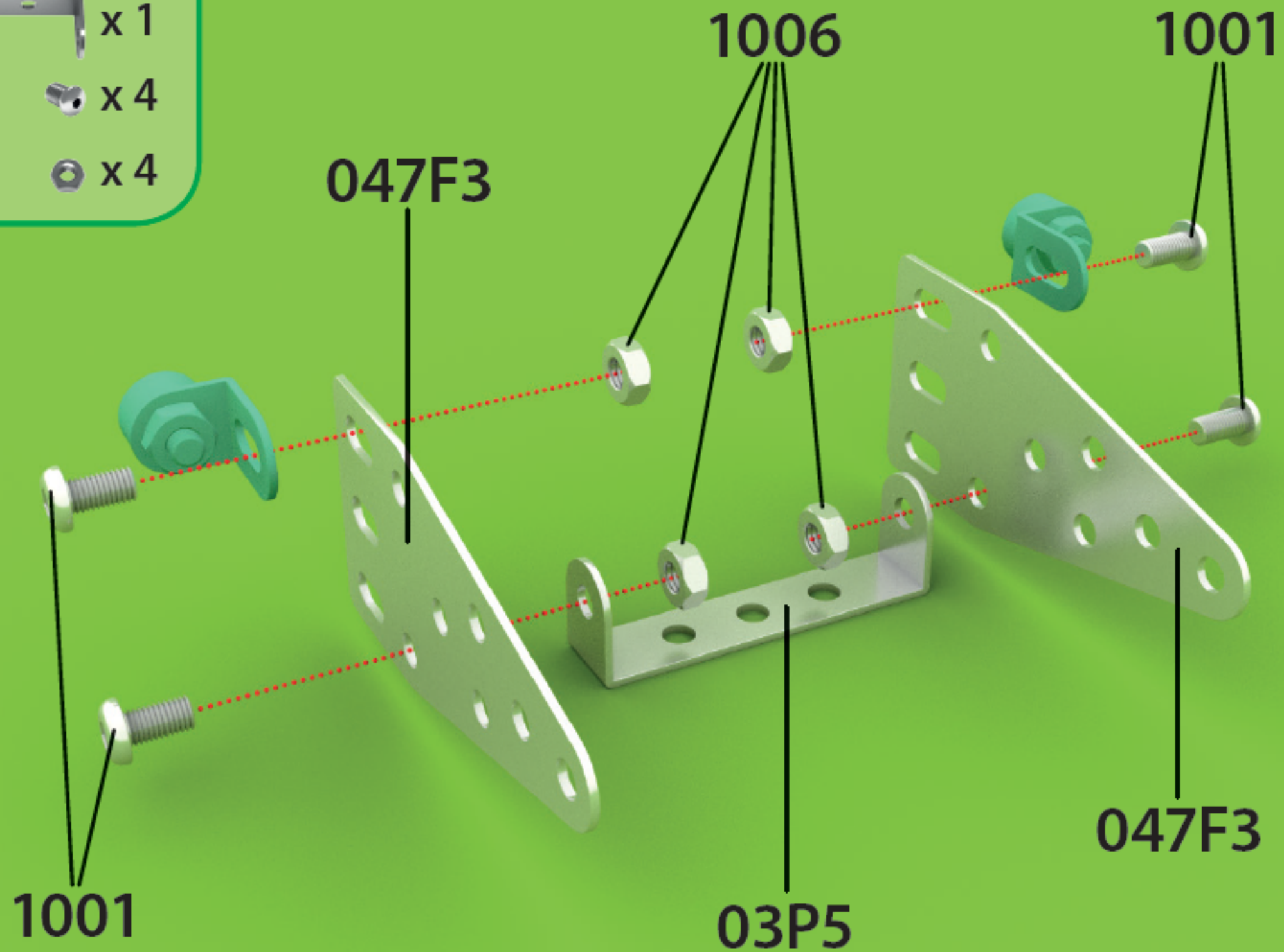

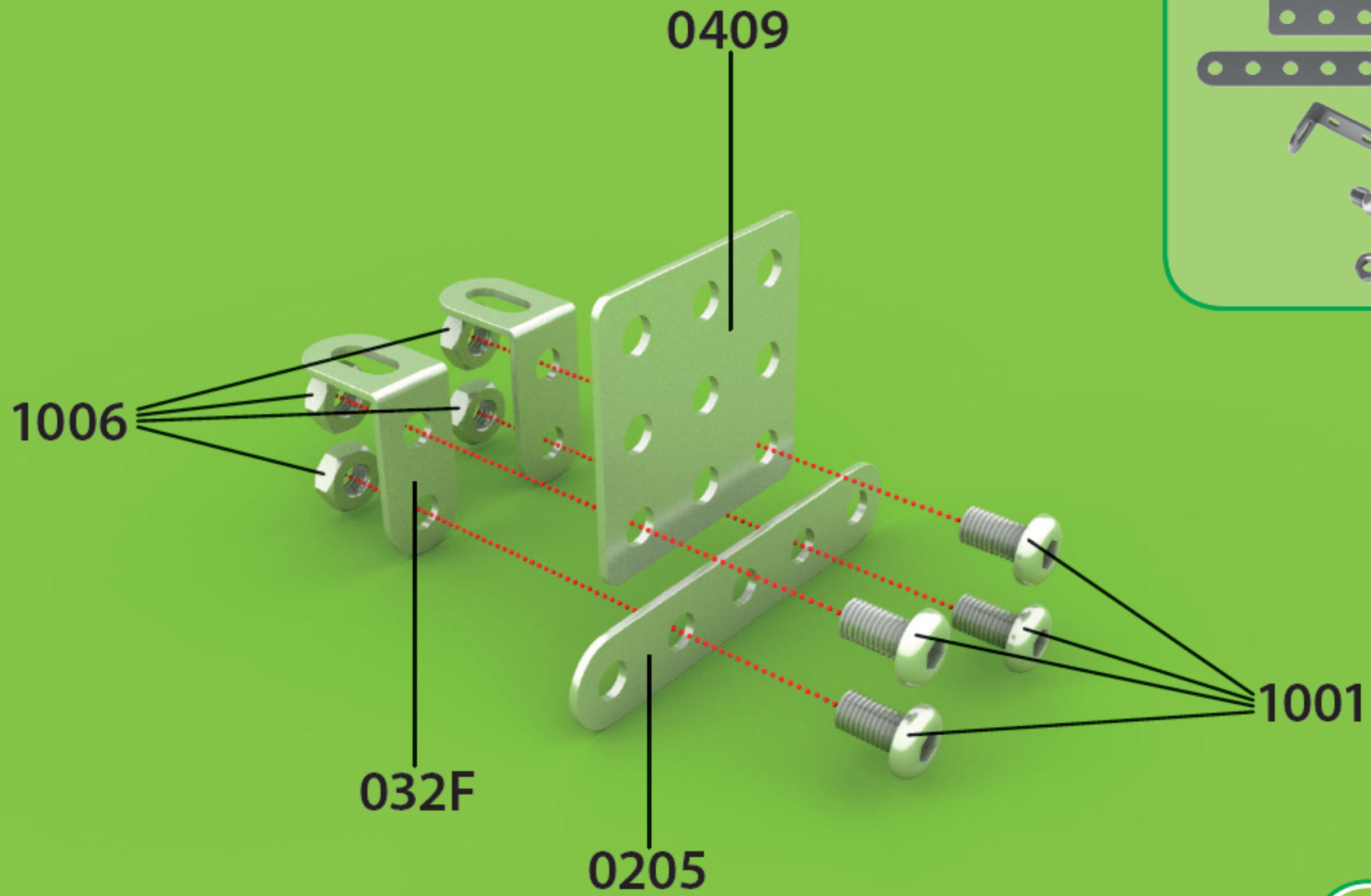
x 4





 x 2

 x 2

 x 2

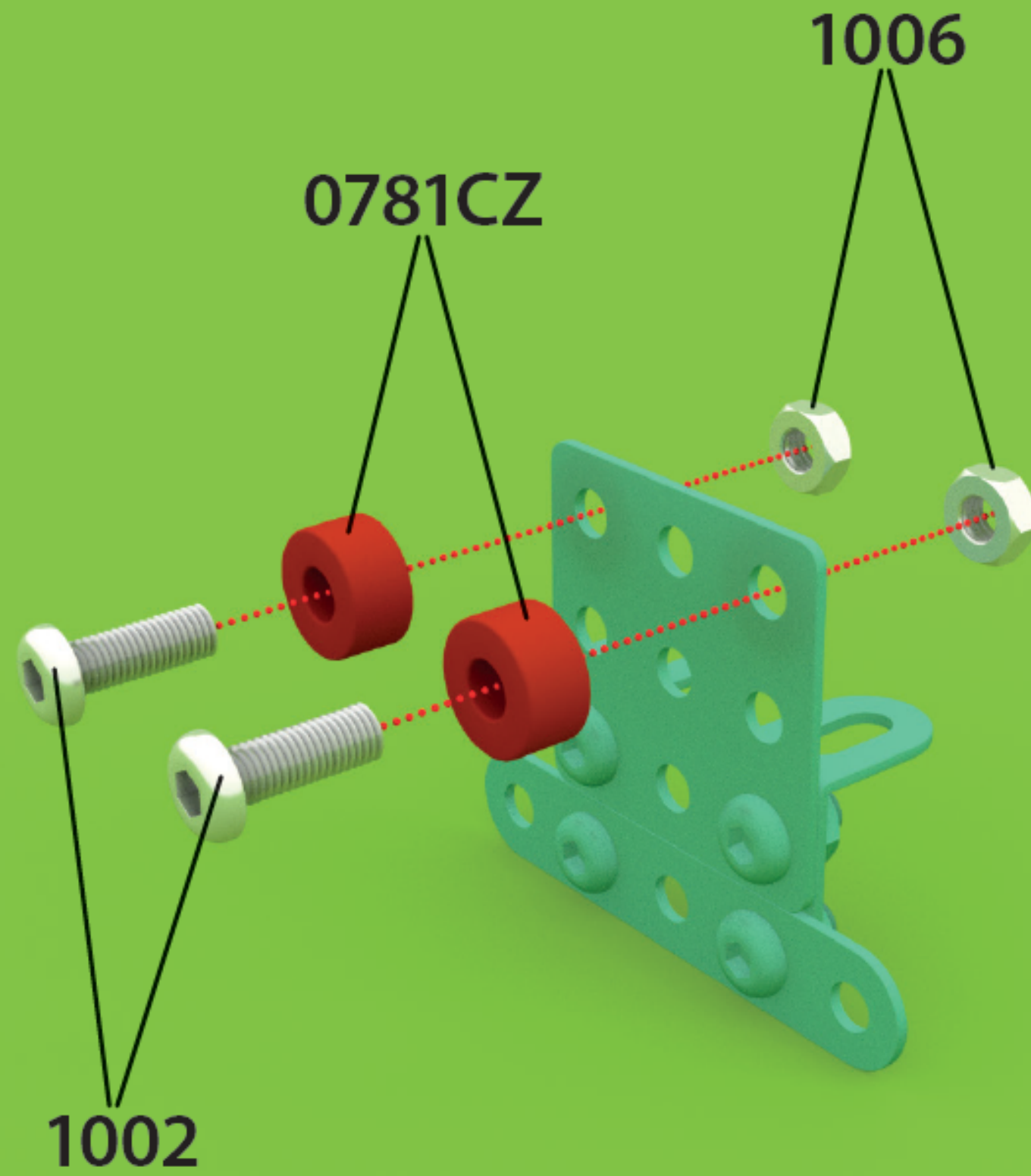

1001

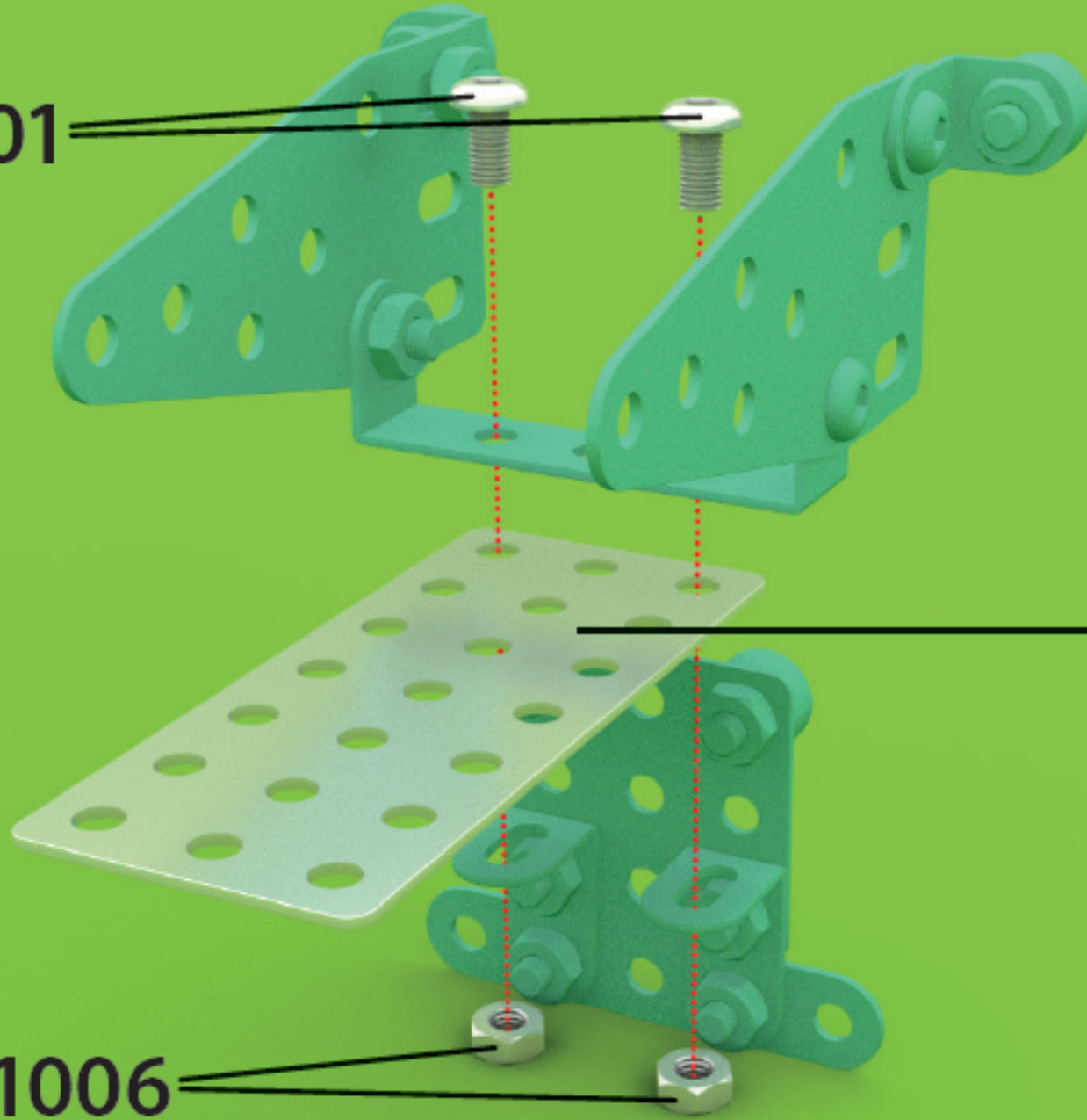

x 1



x 2



x 2

0421

1006



x 1



x 1



x 1



x 1

047D

1001

032F

1006



x 1



x 1





x 1

1003

0410

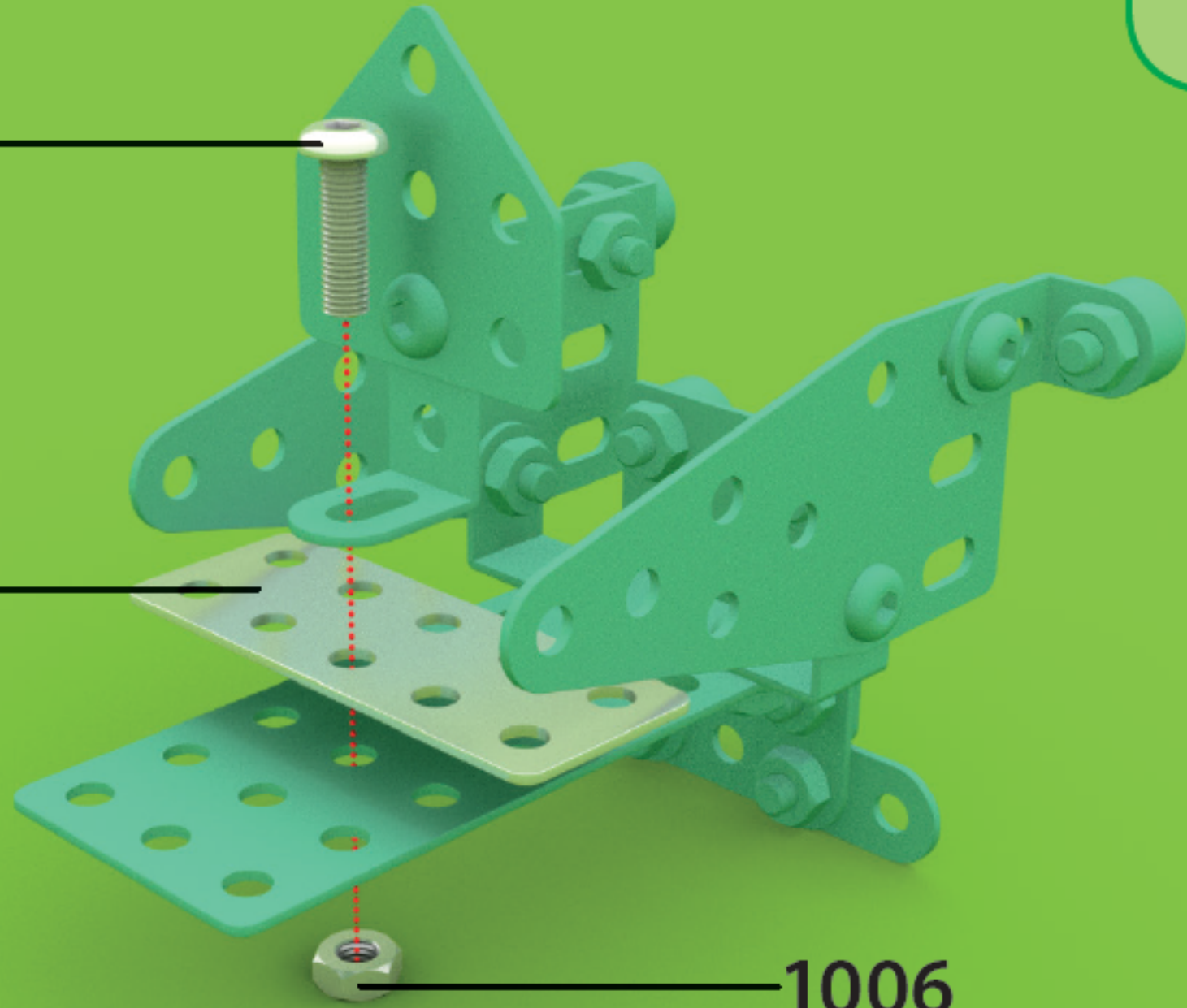
1006



 x 4

 x 2

 x 2

1005

0781Ž

1006

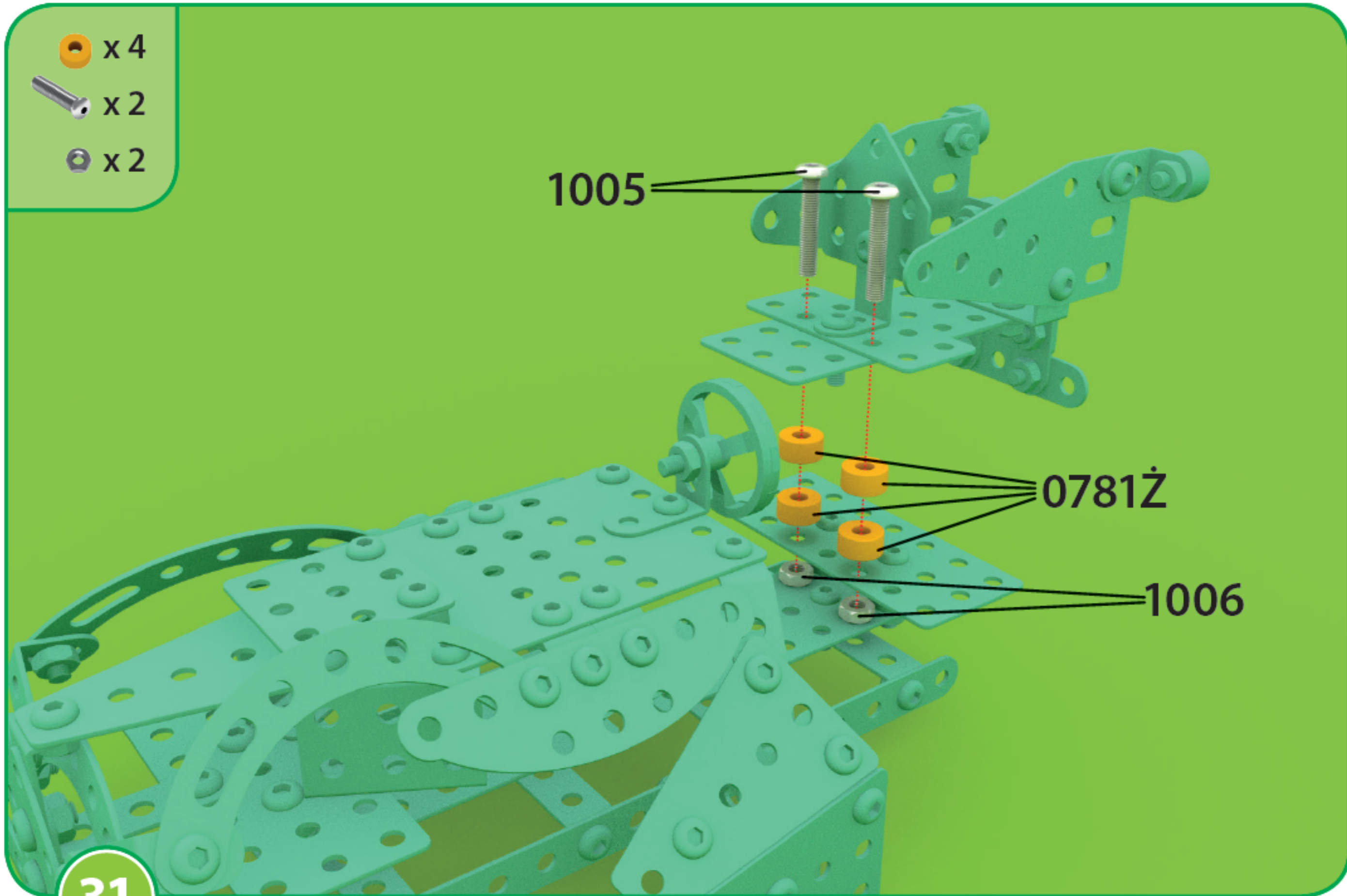

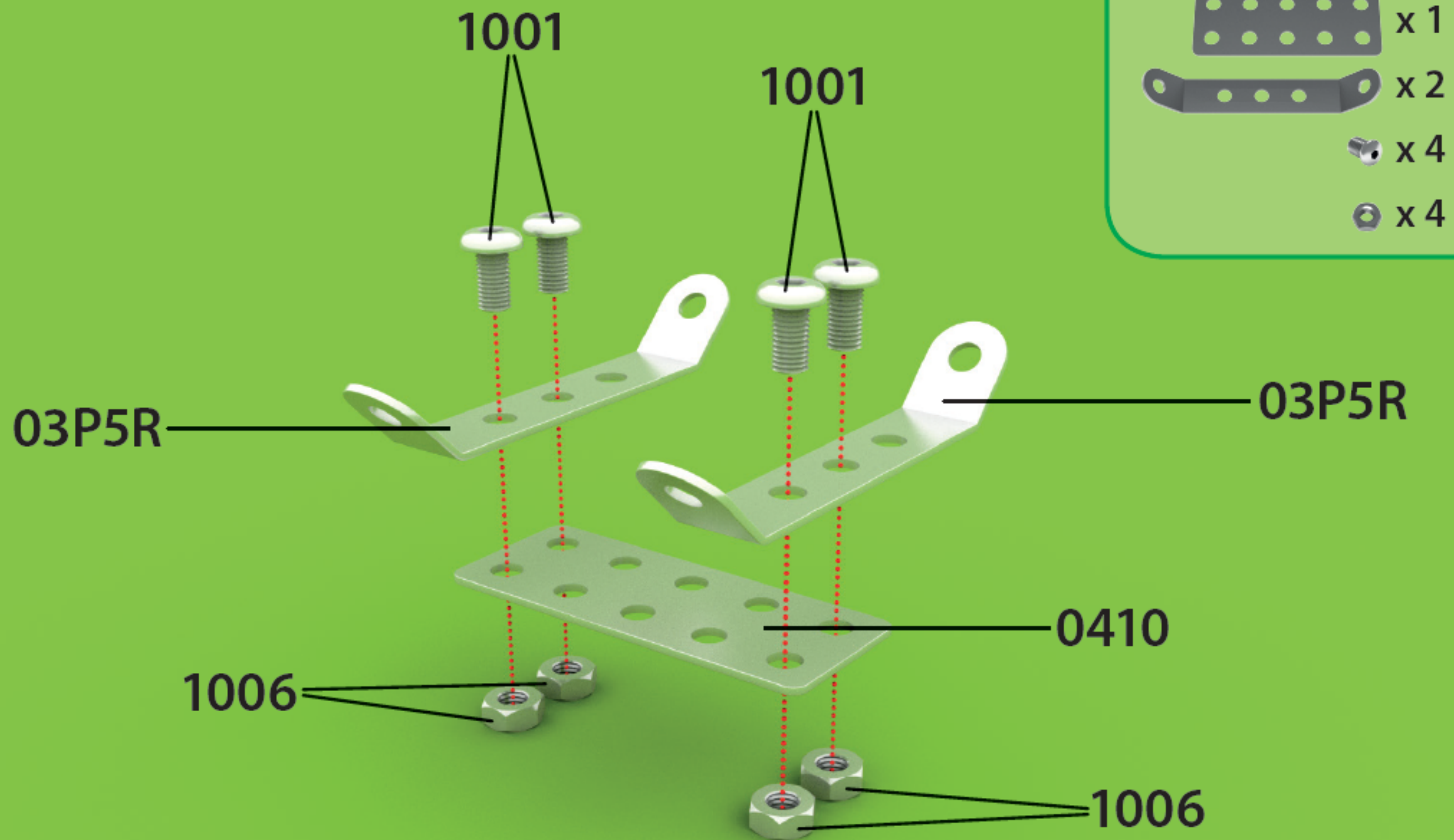



x 1



x 2





x 2

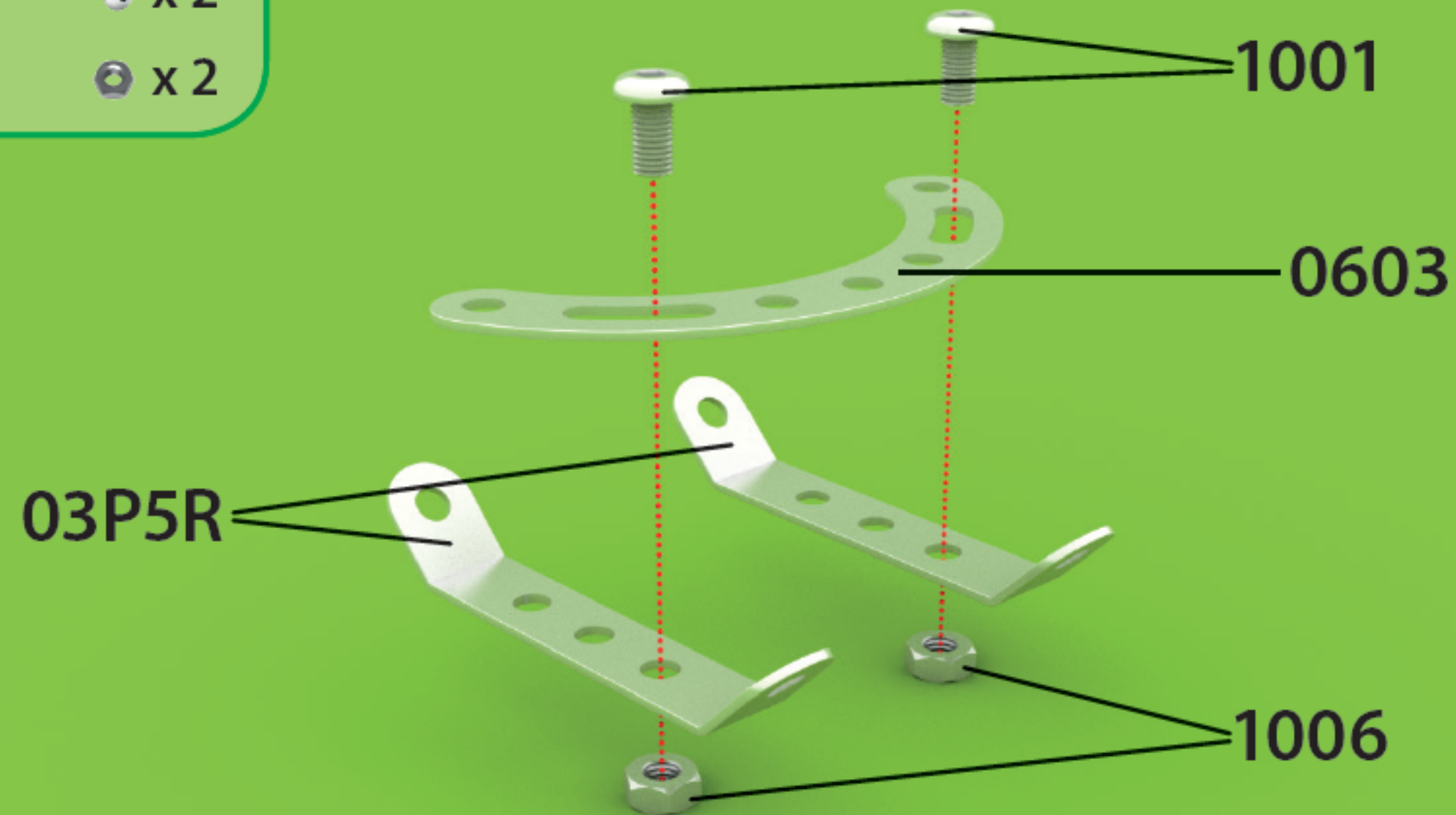

x 2

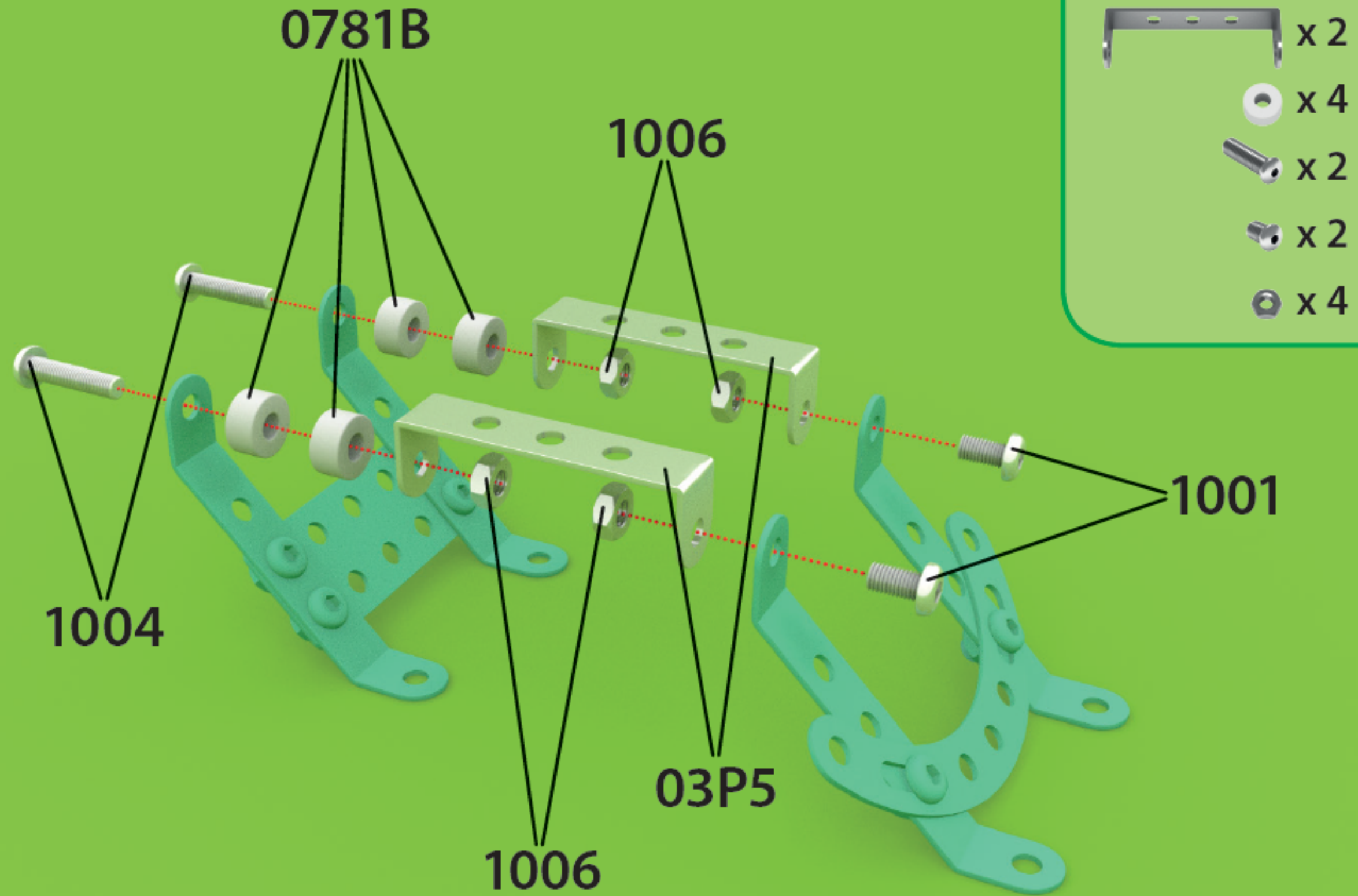



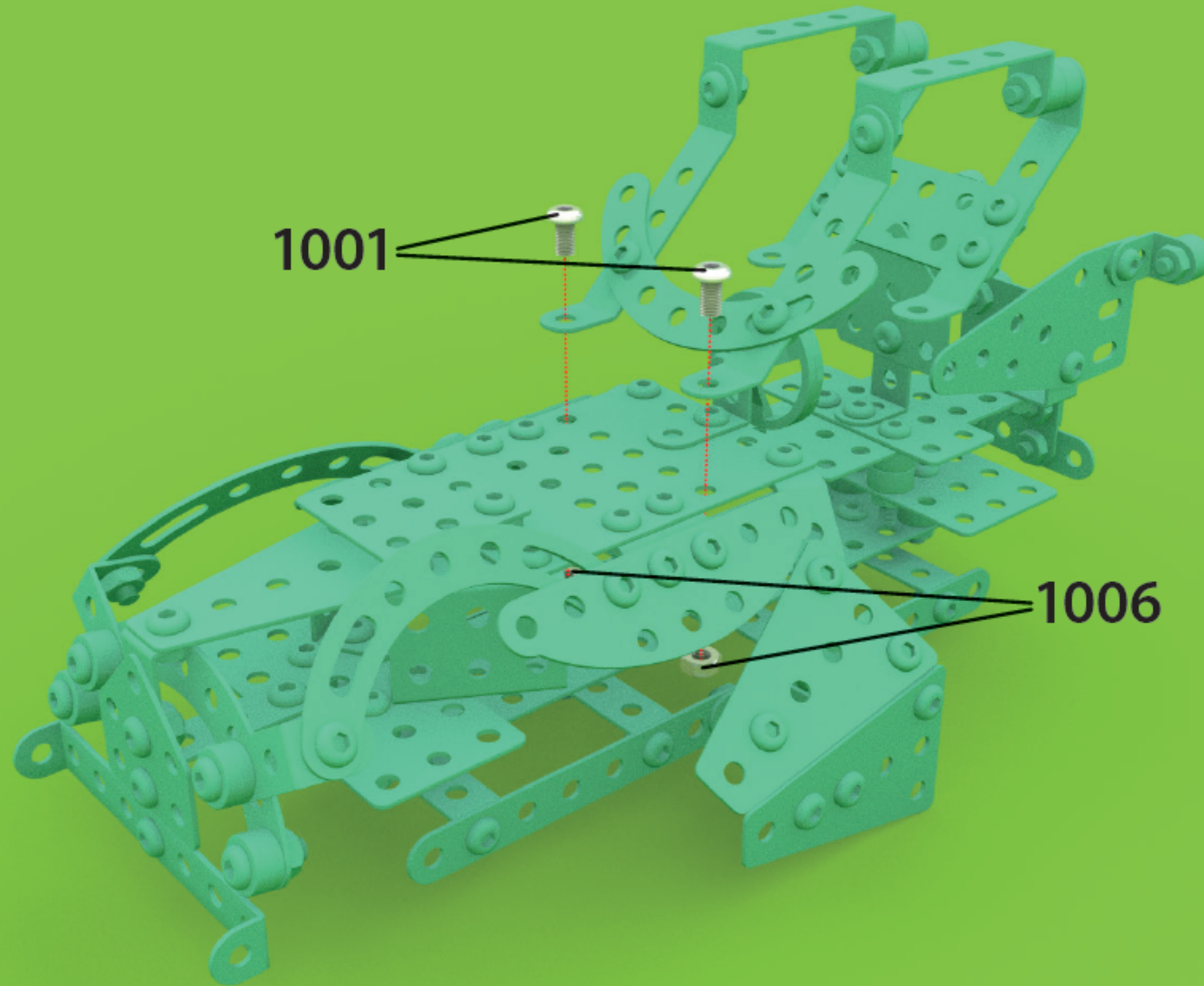

 x 2

 x 2



-  x 4
-  x 2
-  x 2

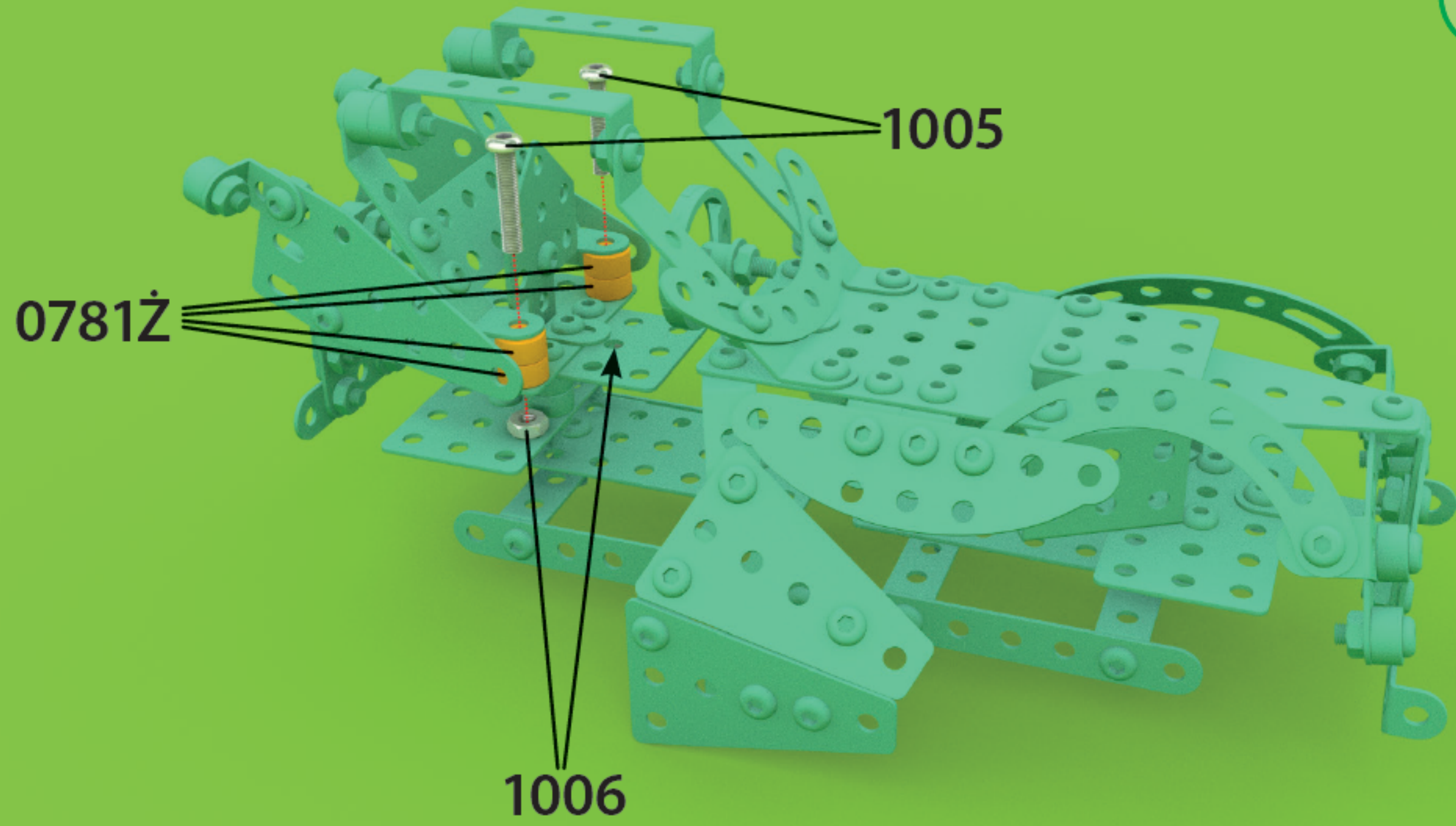

-  x 2
-  x 4
-  x 4
-  x 8

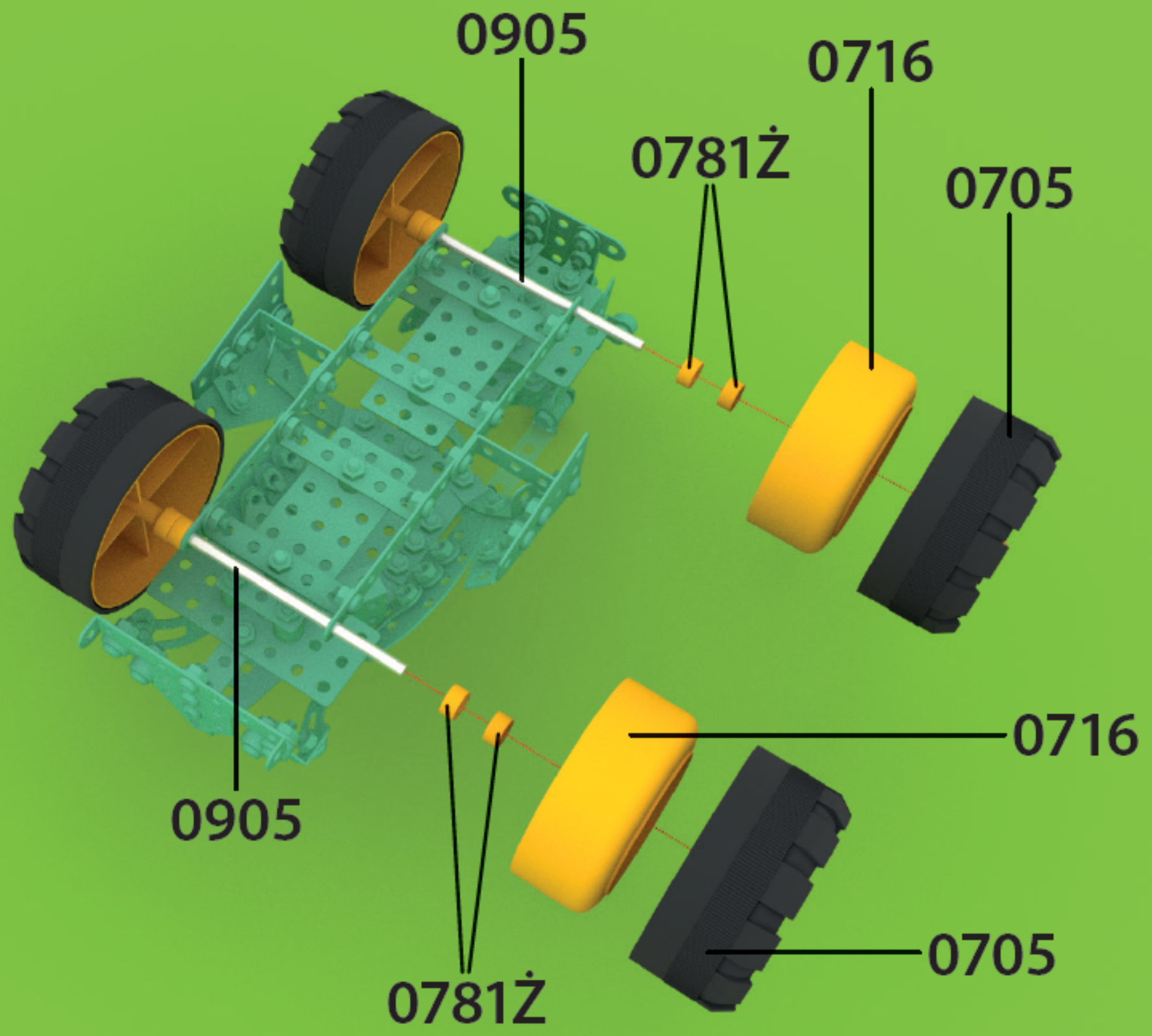

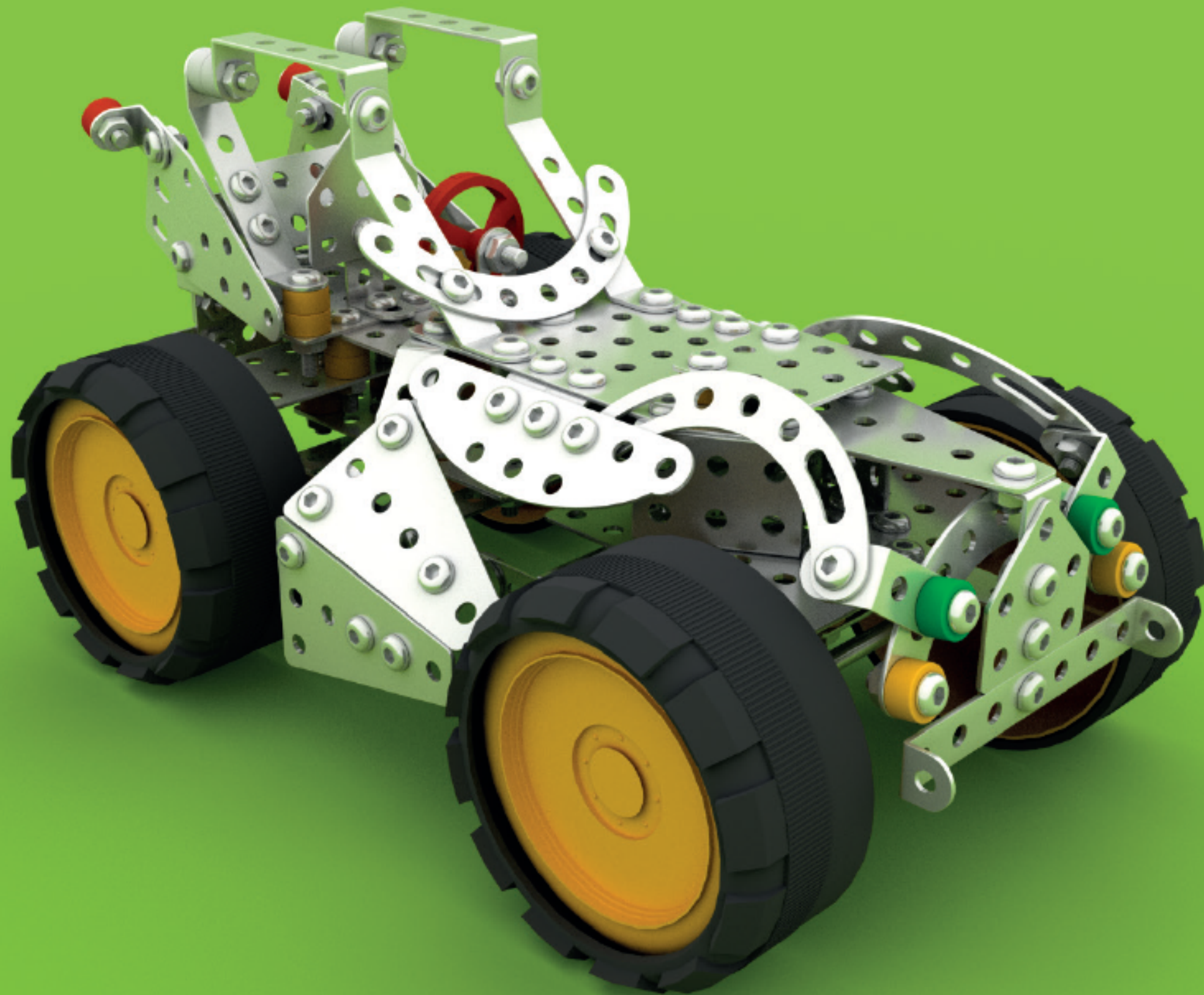



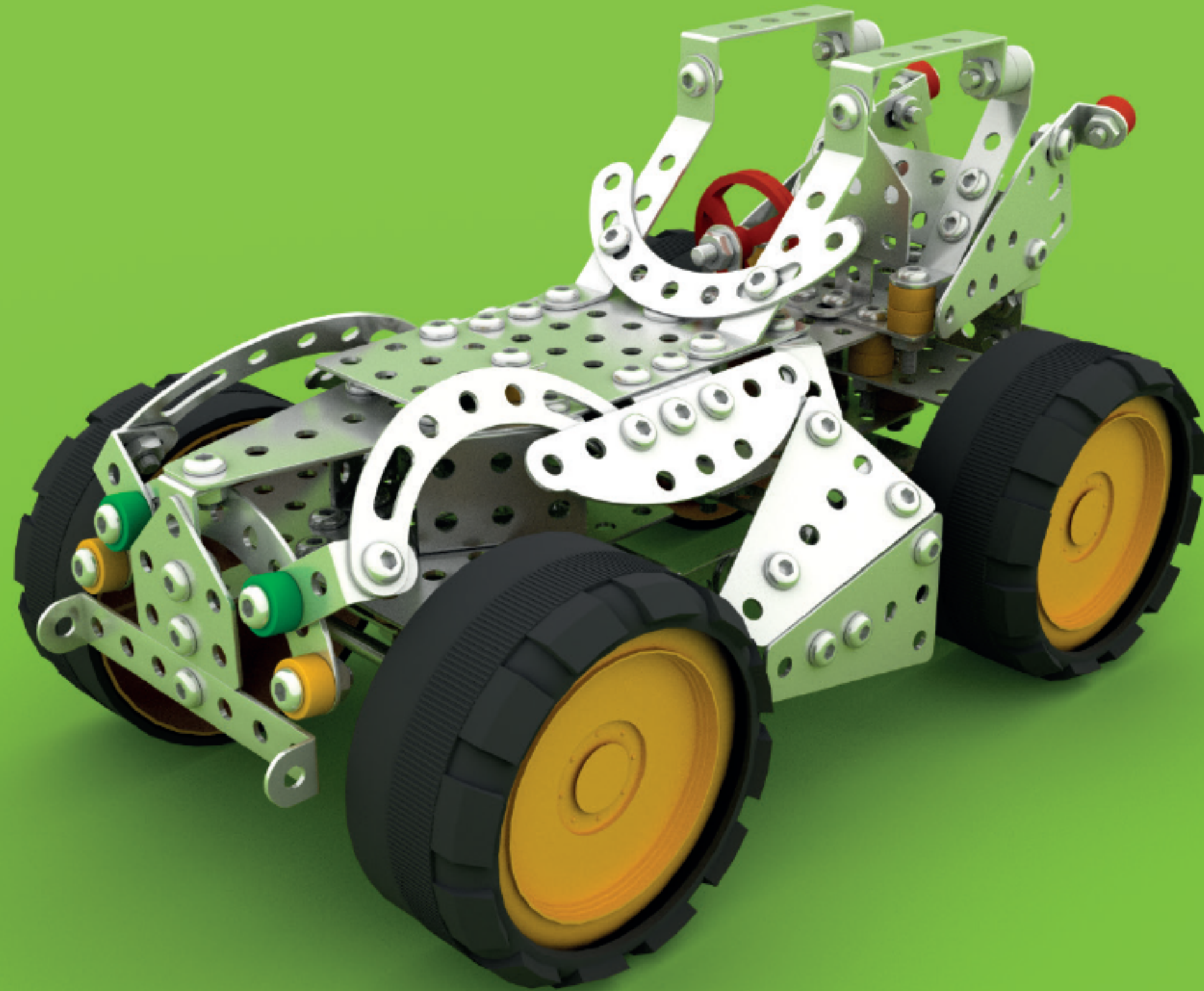

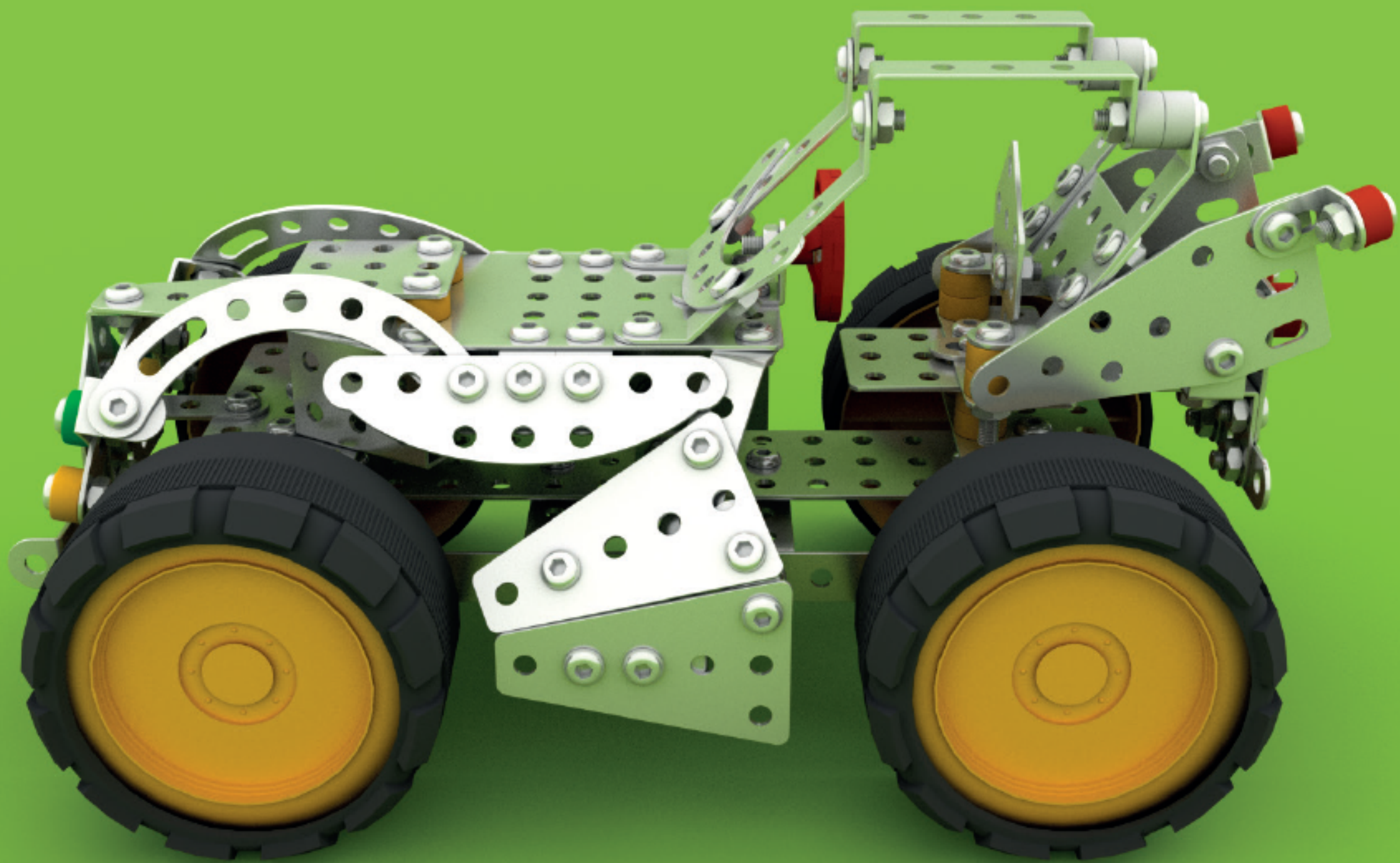

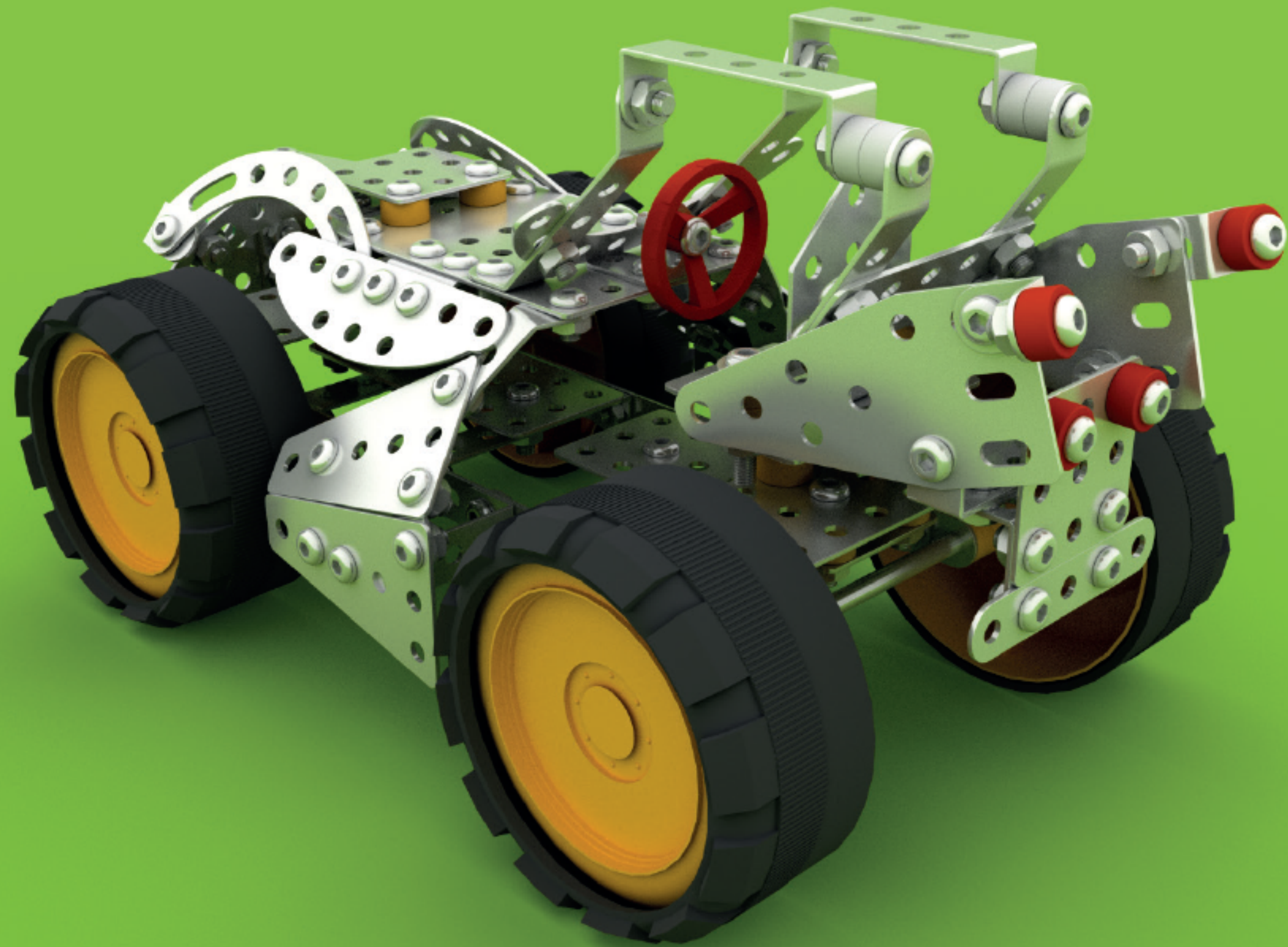

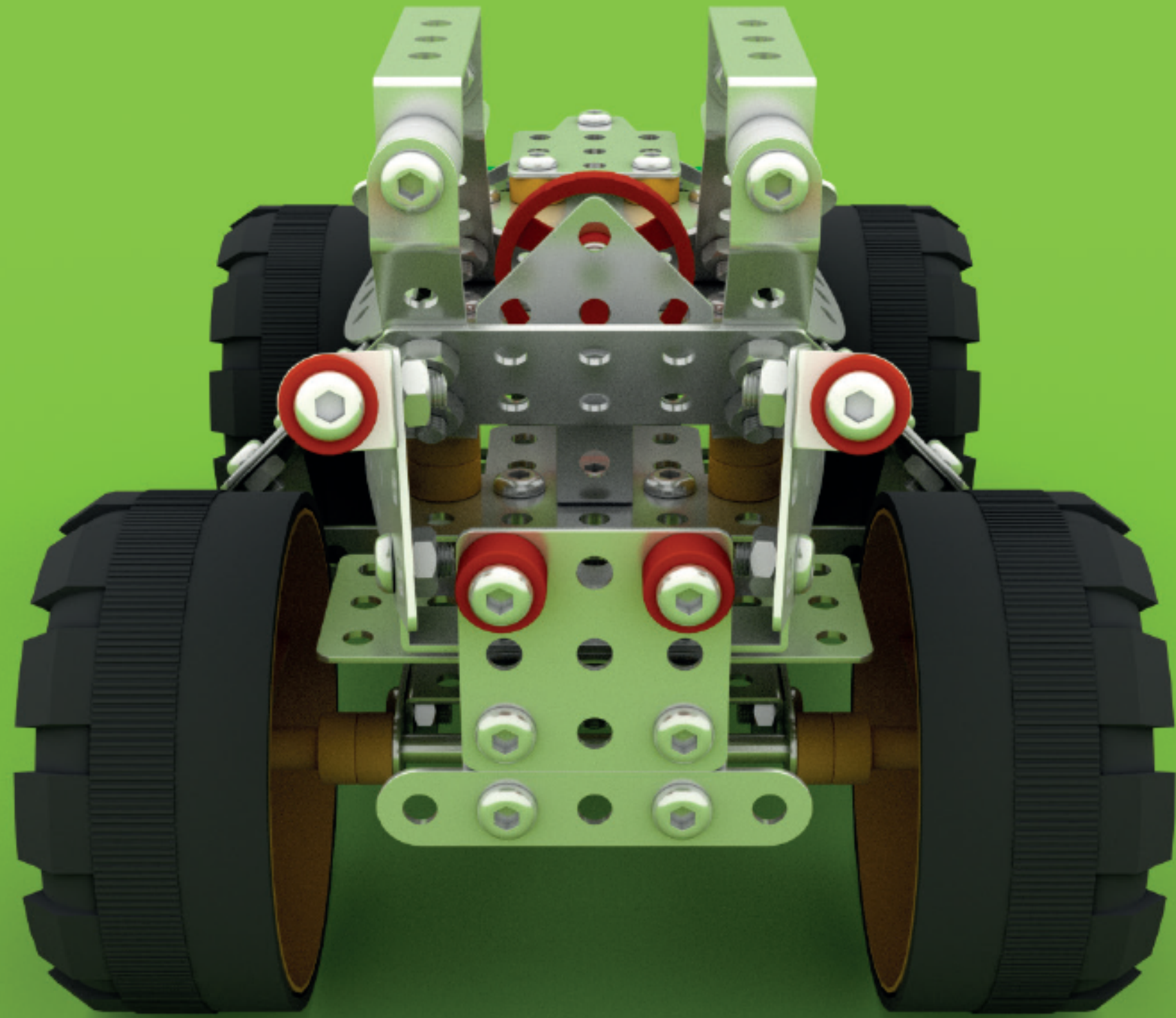

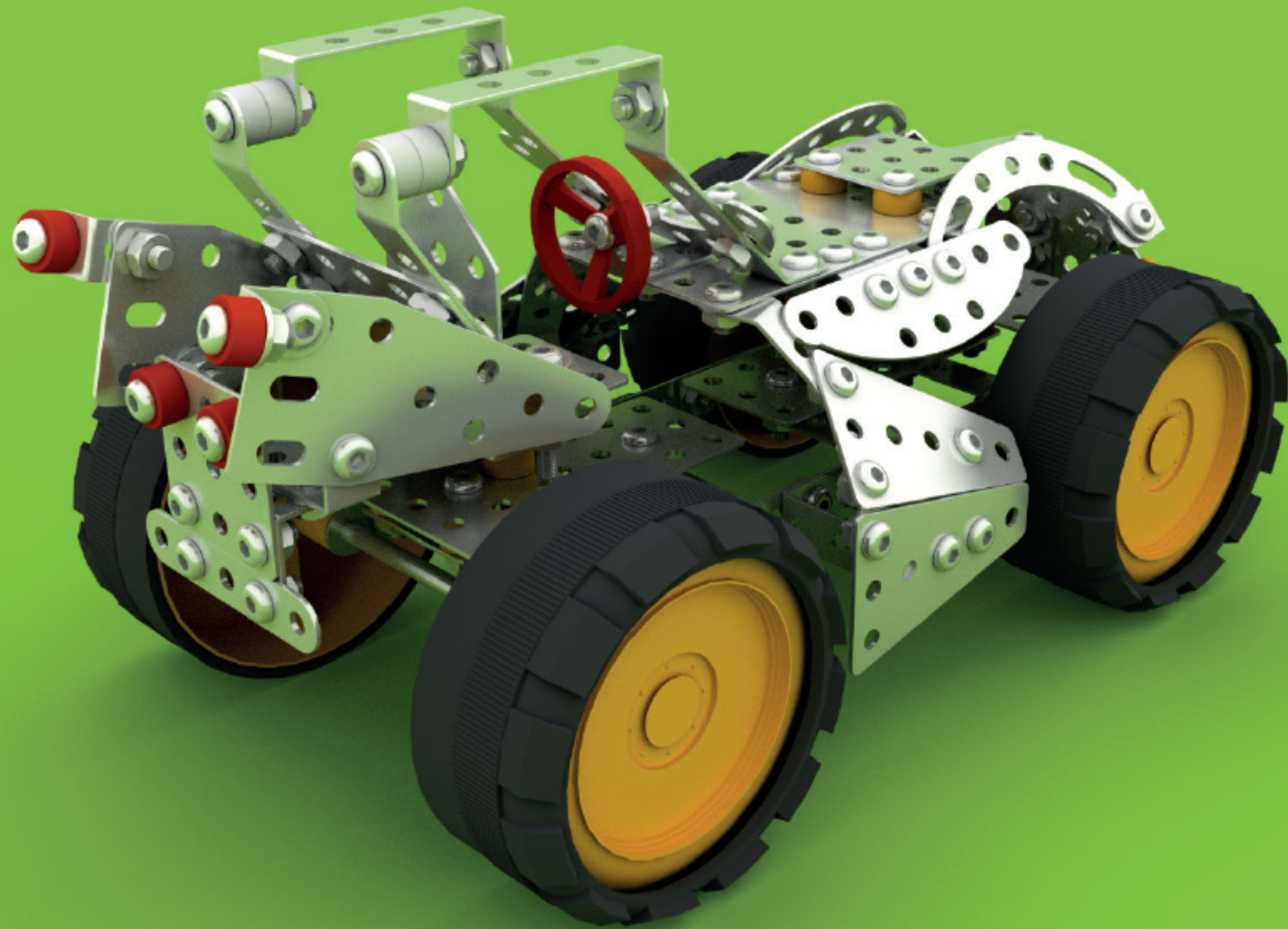

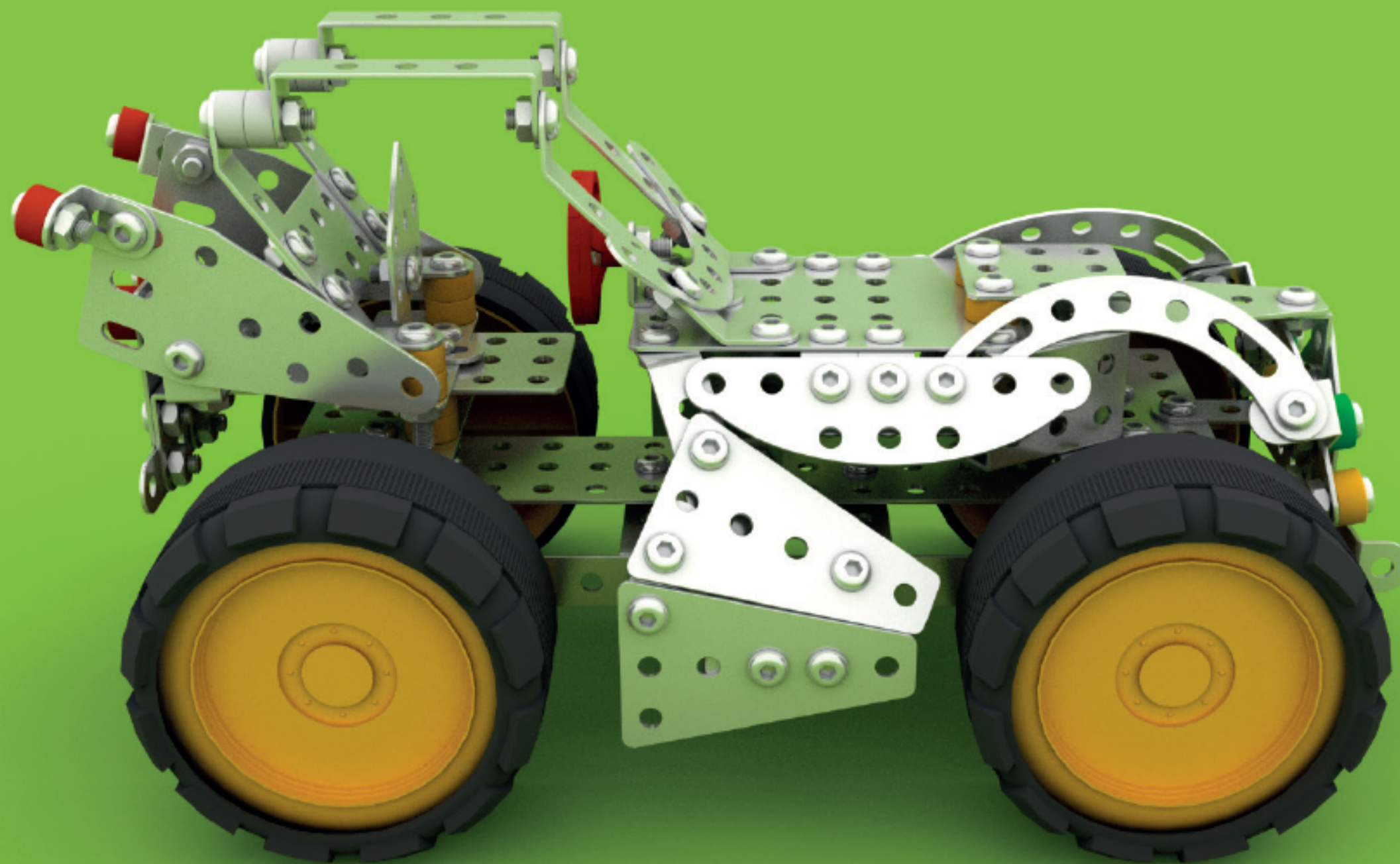

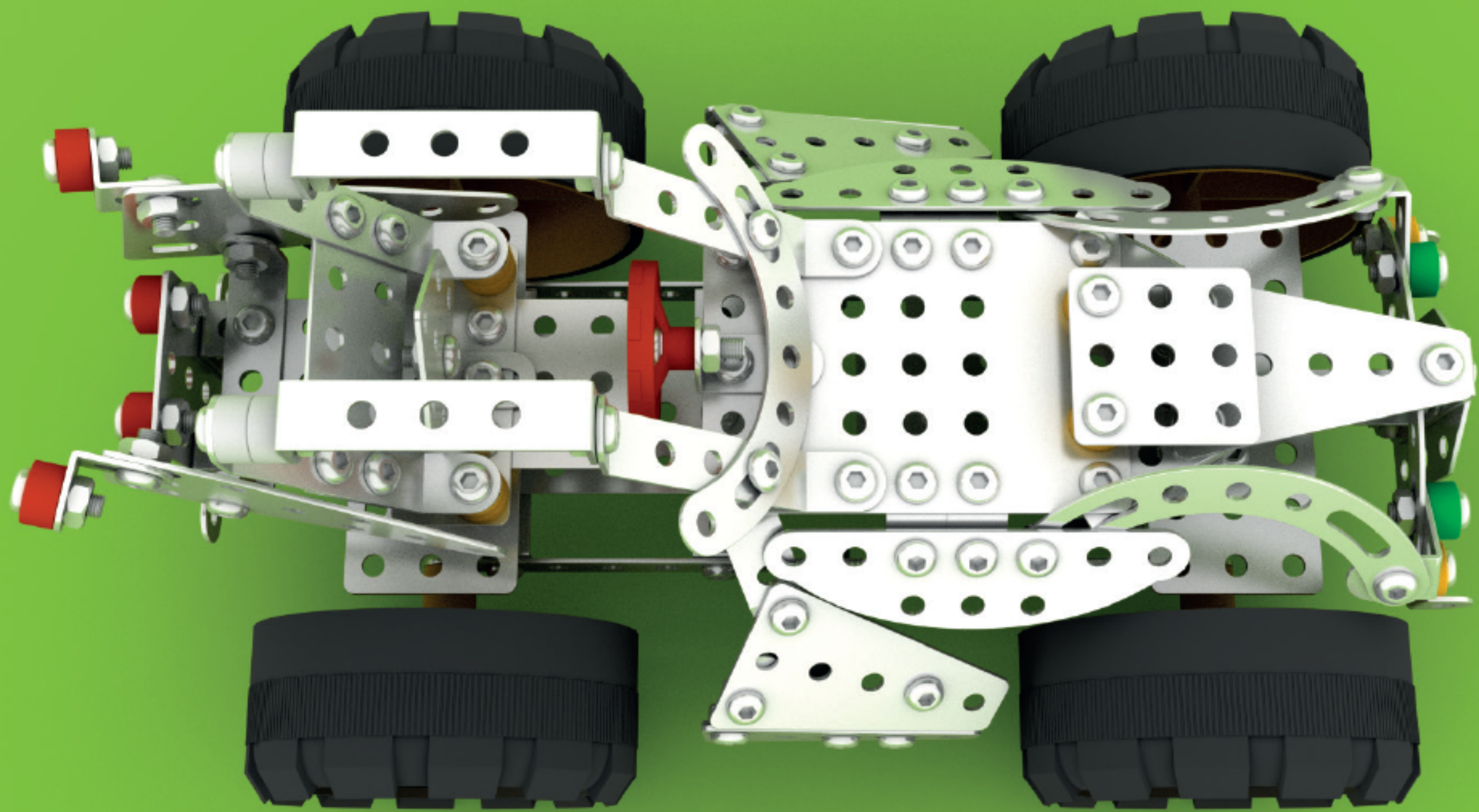

PL: Ostrzeżenia! Nieodpowiednie dla dzieci w wieku poniżej 3 lat. Zestaw zawiera małe elementy – niebezpieczeństwo zakrztuszenia. Prosimy zachować opakowanie ze względu na podane informacje. **EN:** Warnings! Unsuitable for children under the age of 3. Contains small parts – choking hazard. Keep the box for future reference. **DE:** Achtung! Nicht für Kinder unter 3 Jahren geeignet. Enthält kleine Teile, die verschluckt werden können – Erstickungsgefahr. Verpackung für spätere Rückfragen aufbewahren. **FR:** Attention! Ne convient pas aux enfants de moins de 3 ans. Contient des petits éléments pouvant être avalés et engendrer un risque d'étouffement. Documentation à lire et à conserver pour consultation ultérieure. **ES:** ¡Advertencia! No recomendable para niños de 3 años o menores. Peligro de asfixia – piezas pequeñas. Conserve la caja para futuras referencias. **NL:** Waarschuwing! Niet geschikt voor kinderen jonger dan drie jaar. Bevat kleine onderdelen – verstikkingsgevaar opleveren. Bewaar de verpakking, er staat belangrijke informatie op. **CZ:** Upozornění! Nevhodné pro děti do 3 let. Balení obsahuje malé dílky – nebezpečí udušení. Zachovejte prosím obal ze vzhledu na uvedené informace. **SK:** Upozornenia! Nevhodné pre deti vo veku do 3 rokov. Súprava obsahuje malé casti – hrozí nebezpečenstvo udusenía. Obal uschovajte vzhľadom na dôležité informácie, ktoré sa na nom nachádzajú.



2593



www.alexander.com.pl